



BRACKET SKIRT

IT EN

Staffa di raccordo
Connection bracket



D814023 23497_04 26-05-21

GENERALITÀ

Staffa di raccordo per barriere NIGHT&DAY 36 Xtreme e MAXIMA ULTRA 36 con rastrelliera BTM-SKIRT o FULL-SKIRT.



Prima di effettuare qualsiasi intervento sull'impianto togliere l'alimentazione elettrica.



Obbligatoria l'installazione di un sensore di prossimità di tipo E secondo normativa EN 12453 (Device E).



DEMOLIZIONE L'eliminazione dei materiali va fatta rispettando le norme vigenti. Non gettate il vostro apparecchio scartato, le pile o le batterie usate nei rifiuti domestici. Avete la responsabilità di restituire tutti i vostri rifiuti da apparecchiature elettriche o elettroniche lasciandoli in un punto di raccolta dedicato al loro riciclo.

GENERAL INFO

Connection bracket for NIGHT&DAY 36 Xtreme and MAXIMA ULTRA 36 barriers with BTM-SKIRT or FULL-SKIRT rack.



Always disconnect the electricity before attempting any work on the system.



Mandatory installation of an E type proximity sensor according to EN 12453 (Device E).



SCRAPPING Materials must be disposed of in accordance with the regulations in force. Do not throw away your discarded equipment or used batteries with household waste. You are responsible for taking all your waste electrical and electronic equipment to a suitable recycling centre.

A FISSAGGIO BRACKET SKIRT PER BTM-SKIRT BRACKET SKIRT FOR BTM-SKIRT FIXING

1

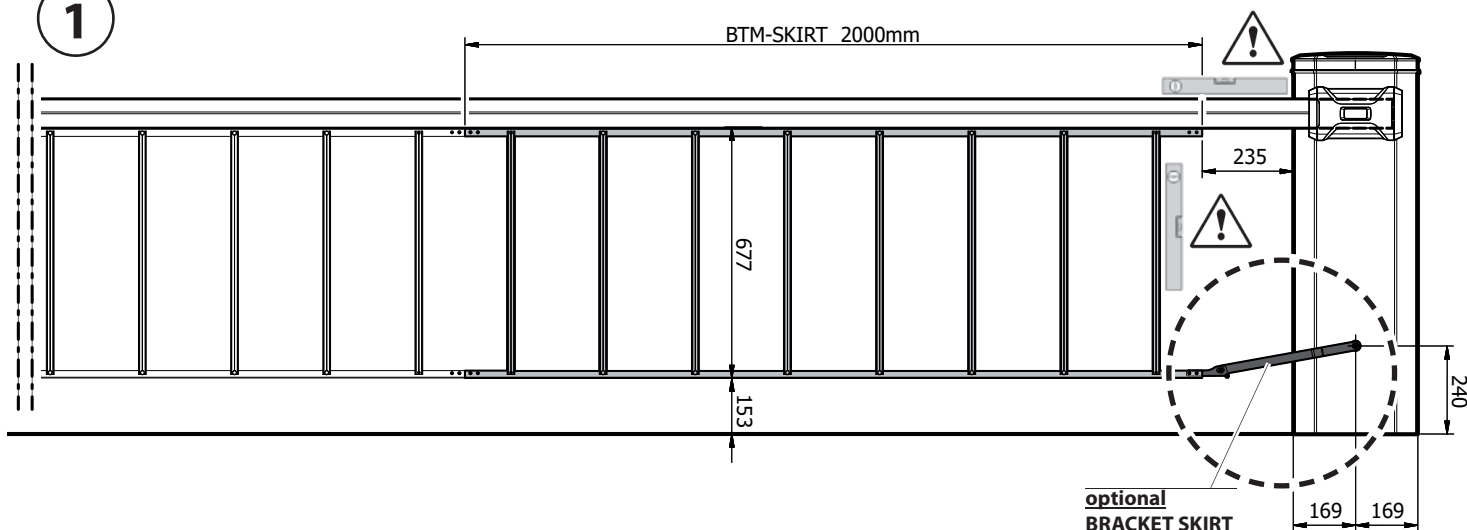

2

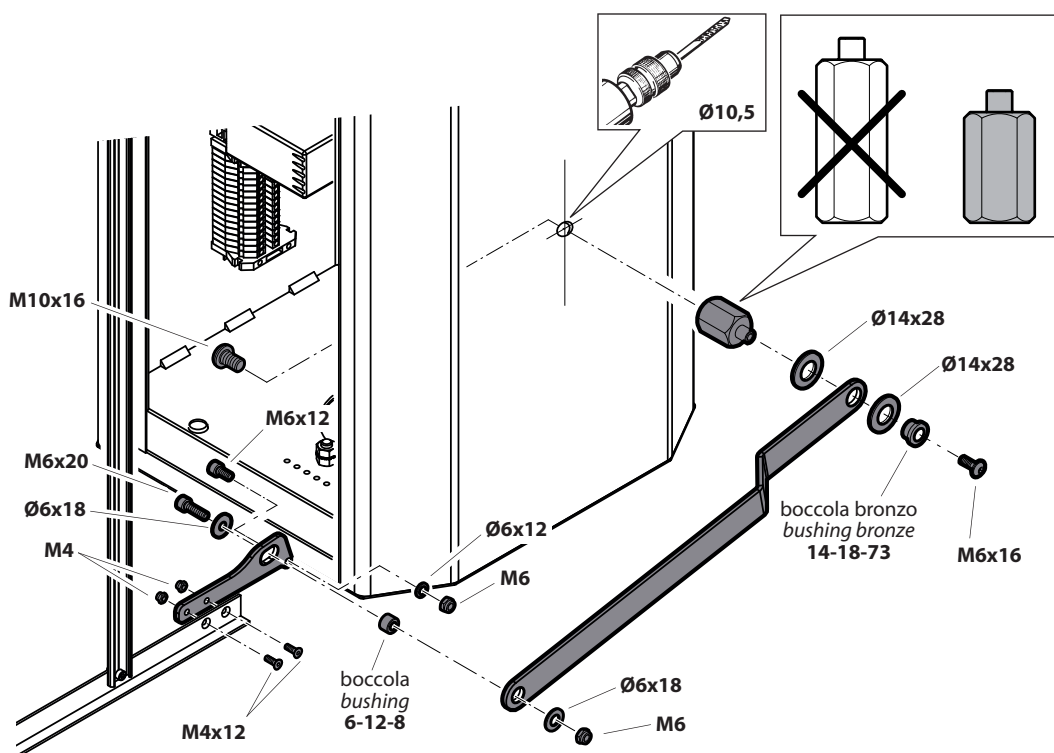

B FISSAGGIO BRACKET SKIRT PER FULL-SKIRT (obbligatorio)
BRACKET SKIRT FOR FULL-SKIRT FIXING (mandatory)

1

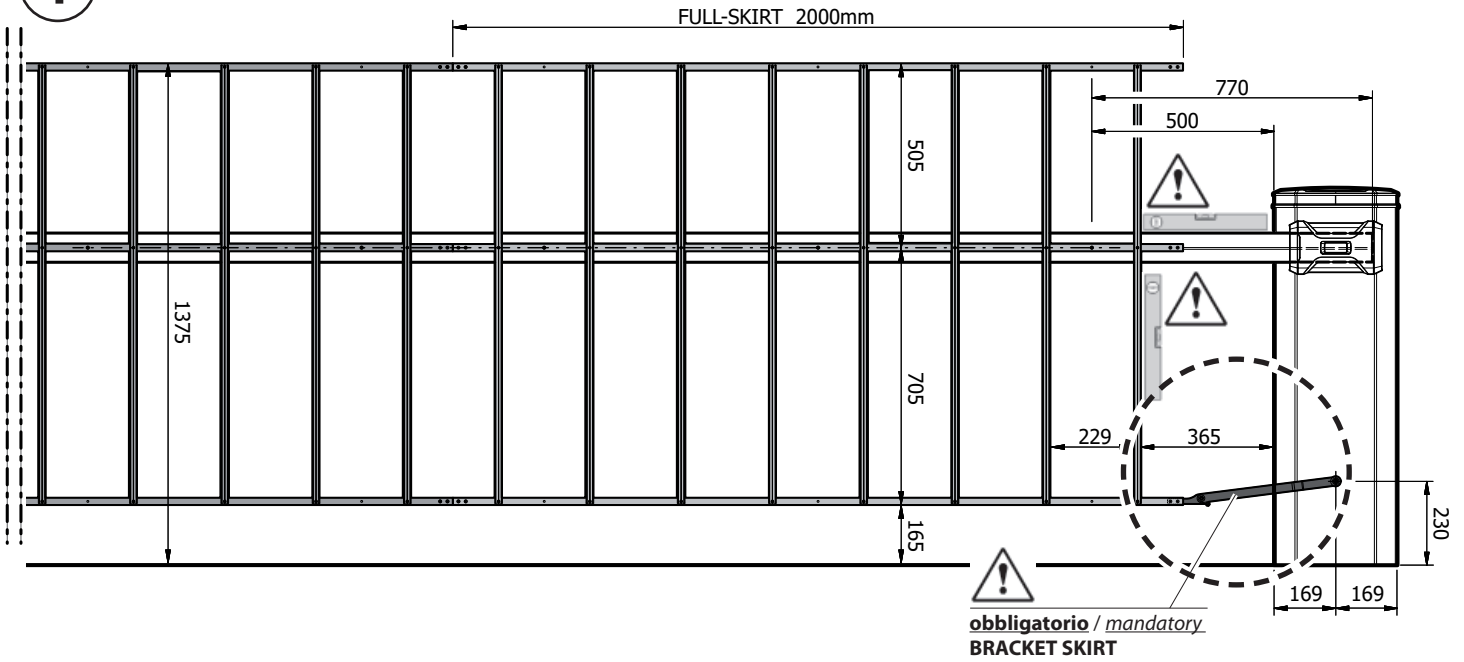

2

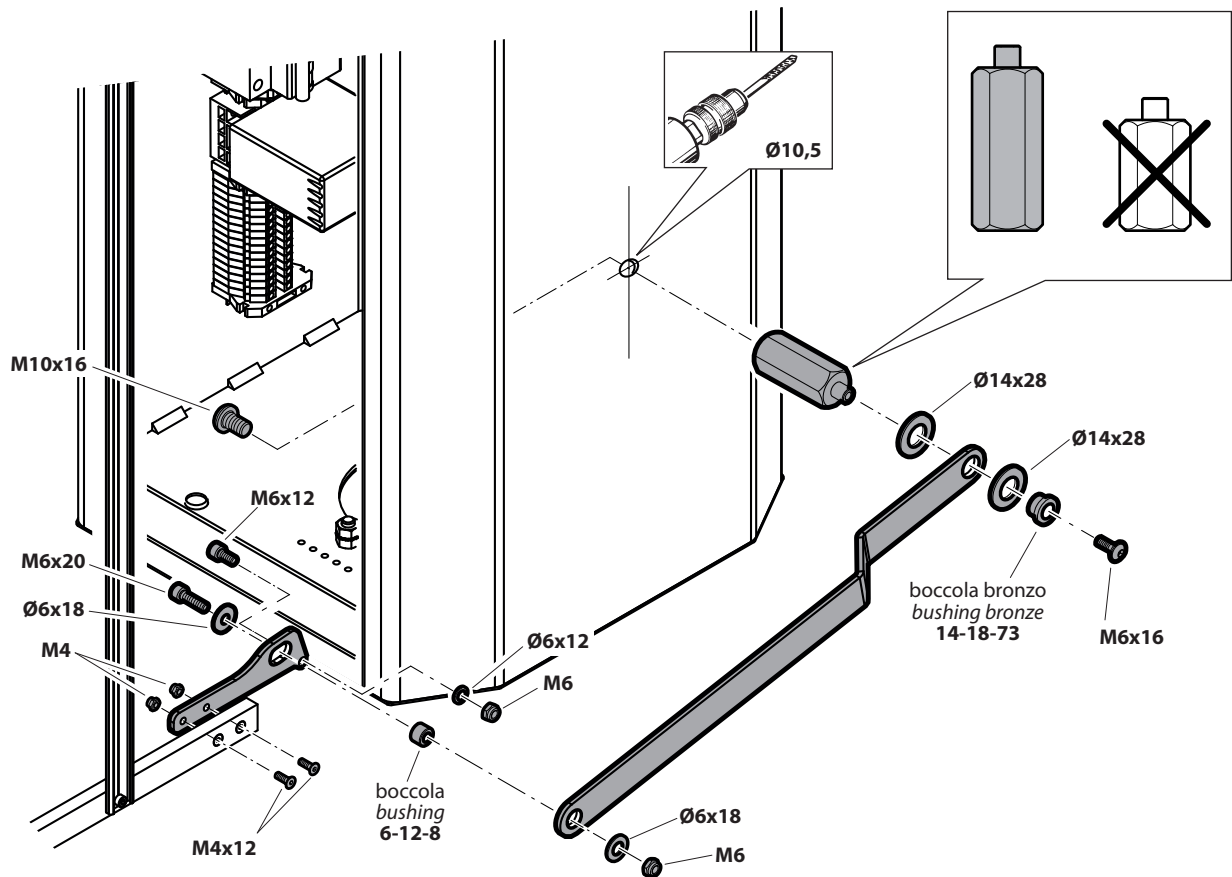

| | | | | |
|---|--|---|---|--|
| <p>www.bft-automation.com</p> <p>BFT Spa</p> <p>Via Lago di Vico, 44 ITALY 36015 Schio (VI) T +39 0445 69 65 11 F +39 0445 69 65 22</p> | <p>SPAIN BFT GROUP ITALIBERICA DE AUTOMATISMOS SL Camí de Can Bassa, 6, 08401 Granollers, Barcelona, Spagna</p> <p>FRANCE AUTOMATISMES BFT FRANCE SAS 50 rue jean zay 69800 Saint-Priest, Francia</p> <p>GERMANY BFT ANTRIEBSSYSTEME GMBH Faber-Castell-Straße 29, 90522 Oberasbach, Germania</p> | <p>UNITED KINGDOM BFT AUTOMATION UK LTD Unit C2-C3 The Embankment Business Park, Vale Road Heaton Mersey Stockport Cheshire SK4 3GLUnited Kingdom</p> <p>BFT AUTOMATION (SOUTH) LTD Enterprise House Murdock Road, Dorcan, Swindon, England, SN3 5HY</p> <p>PORTUGAL BFT PORTUGAL SA Urb. Pedrulha lote 9 - Apartado 8123, 3025-248 Coimbra Portugal</p> <p>POLAND BFT POLSKA SP ZOO Marecka 49, 05-220 Zielonka, Polonia</p> | <p>IRELAND BFT AUTOMATION IRELAND Unit D3 City Link Business Park, Old Naas Road, Dublin</p> <p>CROATIA BFT ADRIA DOO Obrovac 39, 51218, Dražice, Croazia</p> <p>CZECH REPUBLIC BFT CZ SRO Ustecka 533/9, 184 00 Praha 8, Czech</p> <p>TURKEY BFT OTOMASYON KAPI Şerifali Mahallesi, no, 34775 Ümraniye/İstanbul, Turchia</p> | <p>U.S.A. BFT AMERICAS INC. 1200 S.W. 35th Avenue Suite B Boynton Beach FL 33426</p> <p>AUSTRALIA BFT AUTOMATION AUSTRALIA PTY 29 Bentley St, Wetherill Park NSW 2164, Australia</p> <p>EMIRATES BFT MIDDLEEAST FZCO FZS2 AA01 -PO BOX 262200, Jebel Ali Free Zone South Zone 2 , Dubai - United Arab</p> <p>NEW ZEALAND BFT AUTOMATION NEW ZEALAND 224/A Bush Road, Rosedale, Auckland, New Zealand</p> |
|---|--|---|---|--|