

MAXIMA ULTRA 36

TABELLA PER LA TARATURA MOLLE

SPRINGS CALIBRATION TABLE

| | | 2 | 2,25 | 2,5 | 2,75 | 3 | 3,25 | 3,5 | 3,75 | 4 | 4,25 | 4,5 | 4,75 | 5 | 5,25 | 5,5 | 5,75 | 6 |
|--------------------------------|--------------|-----|------|-----|------|-----|------|-----|------|-----|------|-----|------|-----|------|-----|------|-----|
| BOOM PS | | 1 | 1 | 1 | 1 | 1 | 1 | 1 | 1 | 2 | 2 | 2 | 2 | 2 | 2 | 3 | 3 | 3 |
| | | 130 | 130 | 125 | 120 | 110 | 100 | 90 | 85 | 125 | 120 | 115 | 110 | 100 | 90 | 125 | 115 | 110 |
| BOOM PS | + HYPHEN PRO | | | | | | | | | | | 2 | 2 | 2 | 3 | 3 | 3 | 3 |
| | | | | | | | | | | | | 110 | 100 | 90 | 125 | 120 | 110 | 100 |
| BOOM PS | + ADJ-FOOT | | | | | | | | | 2 | 2 | 2 | 2 | 3 | 3 | 3 | 3 | 2 |
| | | | | | | | | | | 110 | 110 | 95 | 90 | 125 | 115 | 110 | 100 | 95 |
| BOOM PS | + ADJ-FOOT | | | | | | | | | | | 2 | 3 | 3 | 3 | 3 | 2 | 2 |
| | + HYPHEN PRO | | | | | | | | | | | 90 | 125 | 120 | 110 | 105 | 95 | 90 |
| BOOM PS + EBB | | 1 | 1 | 1 | 2 | 2 | 2 | 2 | 2 | 2 | 2 | 2 | 2 | 3 | 3 | 3 | 3 | 2 |
| | | 110 | 100 | 90 | 130 | 125 | 120 | 110 | 110 | 95 | 90 | 95 | 90 | 125 | 115 | 110 | 100 | 95 |
| BOOM PS + EBB | + HYPHEN PRO | | | | | | | | | | | 2 | 3 | 3 | 3 | 3 | 2 | 2 |
| | | | | | | | | | | | | 90 | 125 | 120 | 110 | 105 | 95 | 90 |
| BOOM PS + BTM SKIRT | | 1 | 1 | 1 | 2 | 2 | 2 | 2 | 2 | 2 | 3 | 3 | 3 | 3 | 3 | 3 | 3 | 3 |
| | | 115 | 100 | 90 | 125 | 120 | 115 | 105 | 95 | 125 | 120 | 125 | 120 | 110 | 130 | 125 | 120 | 115 |
| BOOM PS + BTM SKIRT | + HYPHEN PRO | | | | | | | | | | | 3 | 3 | 3 | 3 | 3 | 3 | 3 |
| | | | | | | | | | | | | 125 | 115 | 105 | 130 | 130 | 125 | 120 |
| BOOM PS + BTM SKIRT + ADJ-FOOT | | | | | | | | | | 3 | 3 | 3 | 3 | 3 | 3 | 3 | 3 | 3 |
| | | | | | | | | | | 130 | 125 | 115 | 105 | 95 | 130 | 125 | 115 | 110 |
| BOOM PS + BTM SKIRT + ADJ-FOOT | + HYPHEN PRO | | | | | | | | | | | 3 | 3 | 3 | 3 | 3 | 3 | 3 |
| | | | | | | | | | | | | 110 | 100 | 130 | 125 | 120 | 115 | 105 |
| BOOM PS + BTM SKIRT + EBB | | 1 | 2 | 2 | 2 | 2 | 2 | 3 | 3 | 3 | 3 | 3 | 3 | 3 | 3 | 3 | 3 | 3 |
| | | 95 | 125 | 120 | 115 | 105 | 100 | 130 | 125 | 115 | 105 | 95 | 95 | 130 | 125 | 115 | 110 | 110 |
| BOOM PS + BTM SKIRT + EBB | + HYPHEN PRO | | | | | | | | | | | 3 | 3 | 3 | 3 | 3 | 3 | 3 |
| | | | | | | | | | | | | 110 | 100 | 130 | 125 | 120 | 115 | 105 |
| BOOM PS + FULL SKIRT | | 1 | 1 | 2 | 2 | 2 | 2 | 3 | 3 | 3 | 3 | 3 | 3 | 3 | 3 | 3 | 3 | 3 |
| | | 105 | 90 | 130 | 125 | 115 | 100 | 130 | 125 | 115 | 105 | 95 | 95 | 125 | 120 | 110 | 105 | 105 |
| BOOM PS + FULL SKIRT | + HYPHEN PRO | | | | | | | | | | | 3 | 3 | 3 | 3 | 3 | 3 | 3 |
| | | | | | | | | | | | | 110 | 100 | 130 | 125 | 120 | 110 | 100 |
| BOOM PS + FULL SKIRT + EBB | | 2 | 2 | 2 | 2 | 2 | 3 | 3 | 3 | 3 | 3 | 3 | 3 | 3 | 3 | 3 | 3 | 3 |
| | | 130 | 125 | 120 | 115 | 100 | 130 | 125 | 110 | 100 | 90 | 130 | 120 | 110 | 100 | 100 | 100 | 100 |
| BOOM PS + FULL SKIRT + EBB | + HYPHEN PRO | | | | | | | | | | | 3 | 3 | 3 | 3 | 3 | 3 | 3 |
| | | | | | | | | | | | | 100 | 130 | 125 | 115 | 110 | 100 | 100 |

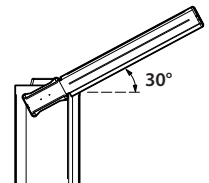
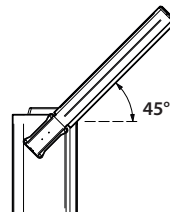

Il valore del prearico è indicativo per raggiungere il corretto angolo di equilibratura sopra indicato. / The preload value is indicative to reach the correct balancing angle indicated above.

Nr. foro / No. hole

2

130

Modello barriera / Barrier type

Prearico (mm) / Preload (mm)

| Colore / Colour | Modello barriera / Barrier type | Filo molla / Spring wire |
|-----------------|---------------------------------|--------------------------|
| | STD Version | Ø 10 mm |
| | XL Version | Ø 11 mm |

FORI AGGANCIAMENTO MOLLA / SPRING COUPLING HOLES

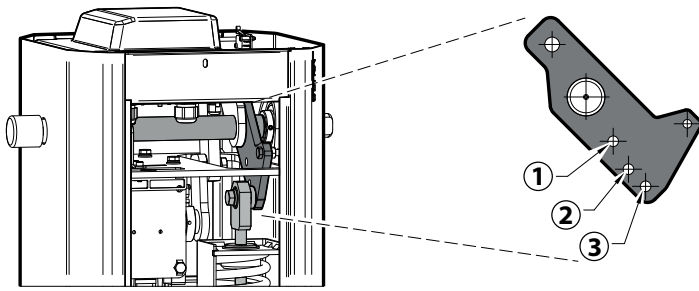

ACCESSORI BARRA / BAR ACCESSORIES

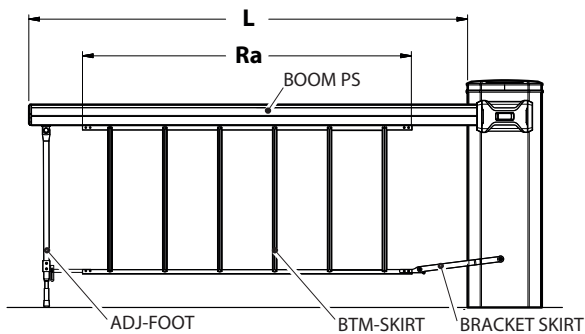

BTM-SKIRT

Ra = L-530 senza / without BRACKET SKIRT

Ra = L-400 con / with BRACKET SKIRT

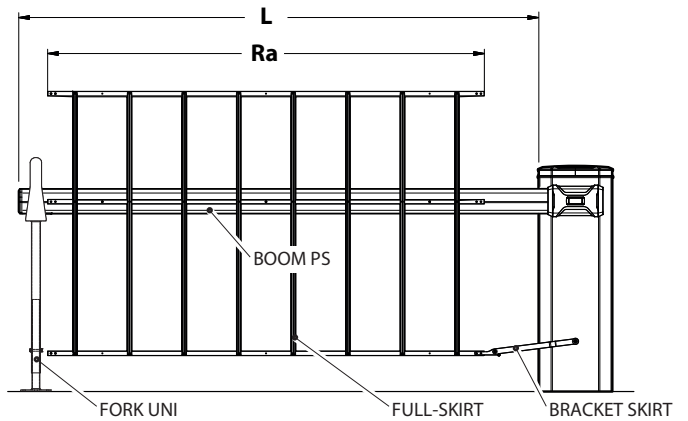

FULL-SKIRT

Ra = L-430 con / with BRACKET SKIRT obbligatorio / required



Non appesantire la barra applicando altri accessori oltre a quelli indicati in tabella

Do not increase the bar weight by applying other accessories not indicated in the table

Bft Spa

Via Largo di Vico, 44 - 36015 Schio (VI) ITALY

T +39 0445 69 65 11

F +39 0445 69 65 22

info@bft.it

www.bft-automation.com



Be ahead