

# FULL-SKIRT PRO

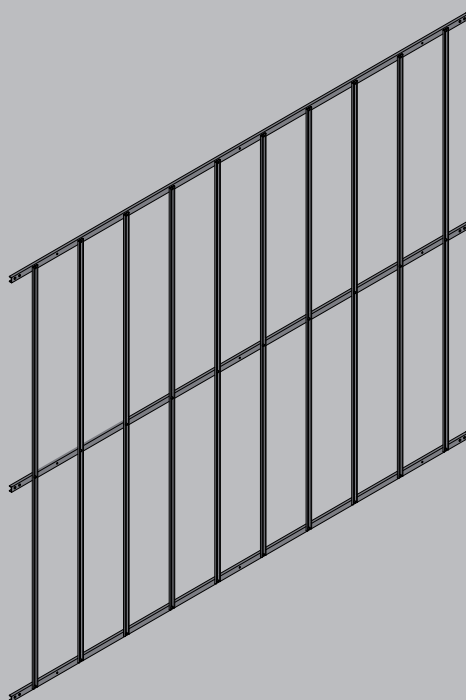

ISTRUZIONI DI INSTALLAZIONE  
INSTALLATION MANUAL

SIEPE DOPPIA PER NIGHT&DAY 68 XTREME/MAXIMA ULTRA 68 CON KIT-PB DOUBLE Xtreme68/OMEGA FRC ATML U  
DOUBLE RACK FOR NIGHT&DAY 68 XTREME/MAXIMA ULTRA 68 WITH KIT-PB DOUBLE Xtreme68/OMEGA FRC ATML U

**Attenzione!** Leggere attentamente le "Avvertenze" all'interno! **Caution!** Read "Warnings" inside carefully!

UK  
CA CE





**GENERALITÀ**

Siepe doppia per aste barriere NIGHT&DAY 68 XTREME/MAXIMA ULTRA 68 con KIT-PB DOUBLE Xtreme68/OMEGA FRC ATML U.

**GENERAL INFO**

Double rack for booms to NIGHT&DAY 68 XTREME/MAXIMA ULTRA 68 barriers with KIT-PB DOUBLE Xtreme68/OMEGA FRC ATML U.

 **Prima di effettuare qualsiasi intervento sull'impianto togliere l'alimentazione elettrica.**

 **DEMOLIZIONE** L'eliminazione dei materiali va fatta rispettando le norme vigenti. Non gettate il vostro apparecchio scartato, le pile o le batterie usate nei rifiuti domestici. Avete la responsabilità di restituire tutti i vostri rifiuti da apparecchiature elettriche o elettroniche lasciandoli in un punto di raccolta dedicato al loro riciclo.

 **Always disconnect the electricity before attempting any work on the system.**

 **SCRAPPING** Materials must be disposed of in accordance with the regulations in force. Do not throw away your discarded equipment or used batteries with household waste. You are responsible for taking all your waste electrical and electronic equipment to a suitable recycling centre.

**COMPOSIZIONE DEL KIT - KIT COMPOSITION**

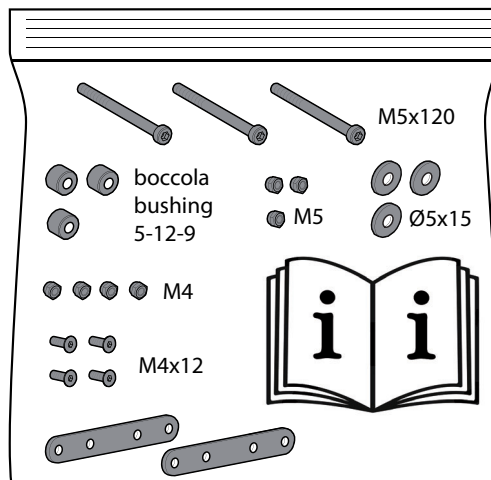
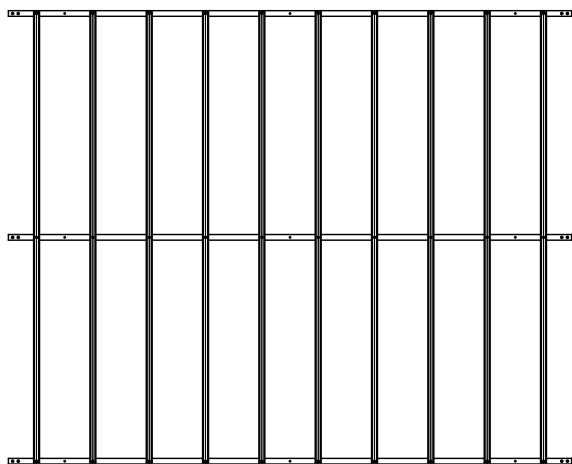

**ATTREZZATURE - EQUIPMENT**

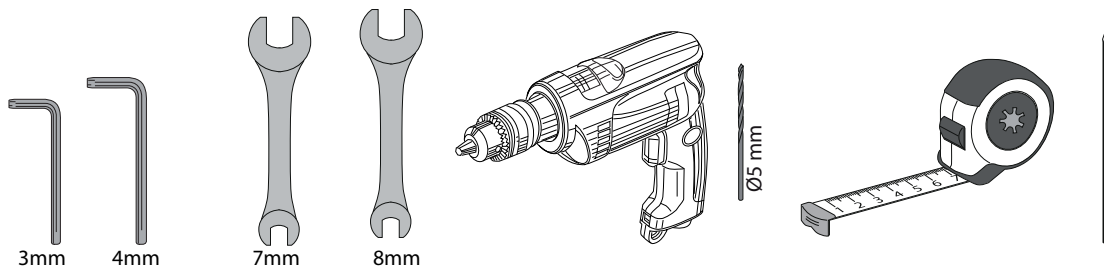

**A DIMENSIONI DIMENSIONS**

 **TUTTE LE DIMENSIONI IN mm - ALL DIMENSIONS IN mm**

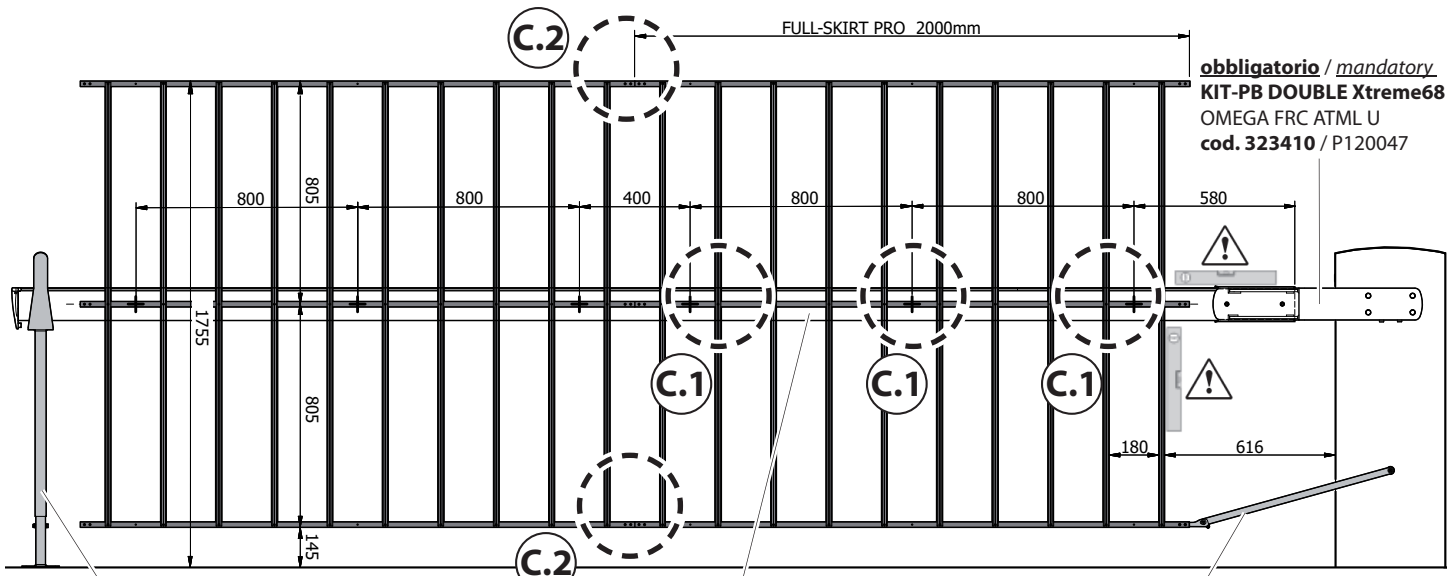

**consigliato / recommended**  
**FORK-UNI / FAF UNI R**  
**cod. 324082-U / P120080**

**BL-LARGE/ATML**

 **obbligatorio / mandatory**  
**BRACKET SKIRT PRO 68 DOUBLE**  
**cod. P120096**

**B** ESEMPI DI INSTALLAZIONE  
INSTALLATION EXAMPLES

**1** BARRA CON FULL-SKIRT  
BAR WITH FULL SKIRT

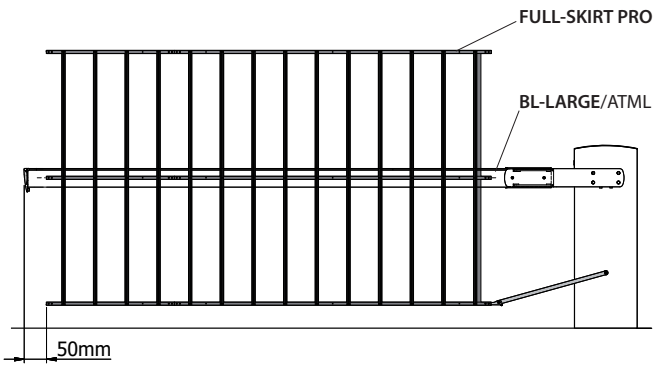

**2** BARRA CON FULL-SKIRT E FORK-UNI/FAF UNI R (Forcella regolabile)  
BAR WITH FULL SKIRT AND FORK-UNI/FAF UNI R (Adjustable fork)

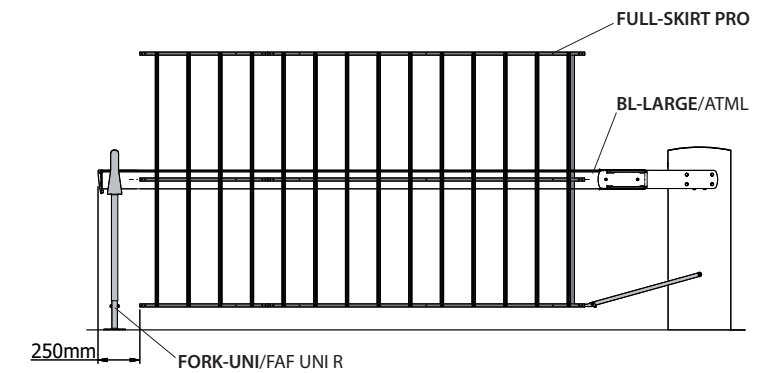

**C** INSTALLAZIONE  
INSTALLATION

**1** FISSARE LA SIEPE DOPPIA ALLA BARRA  
FIX THE DOUBLE RACK TO THE BOOM

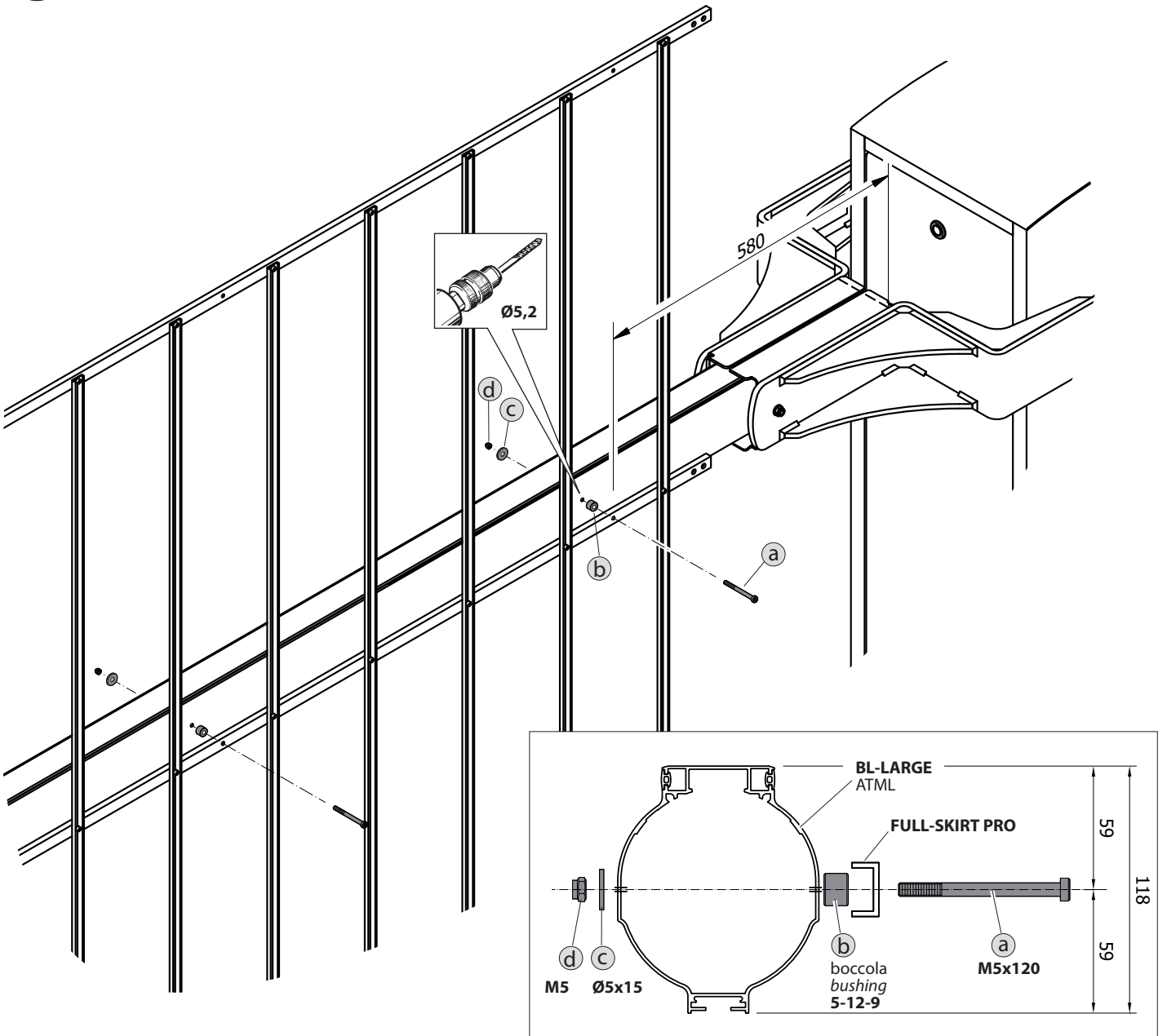

**2** FISSARE LE PARTI DI SIEPE DOPPIA  
FIX THE PARTS OF DOUBLE RACK

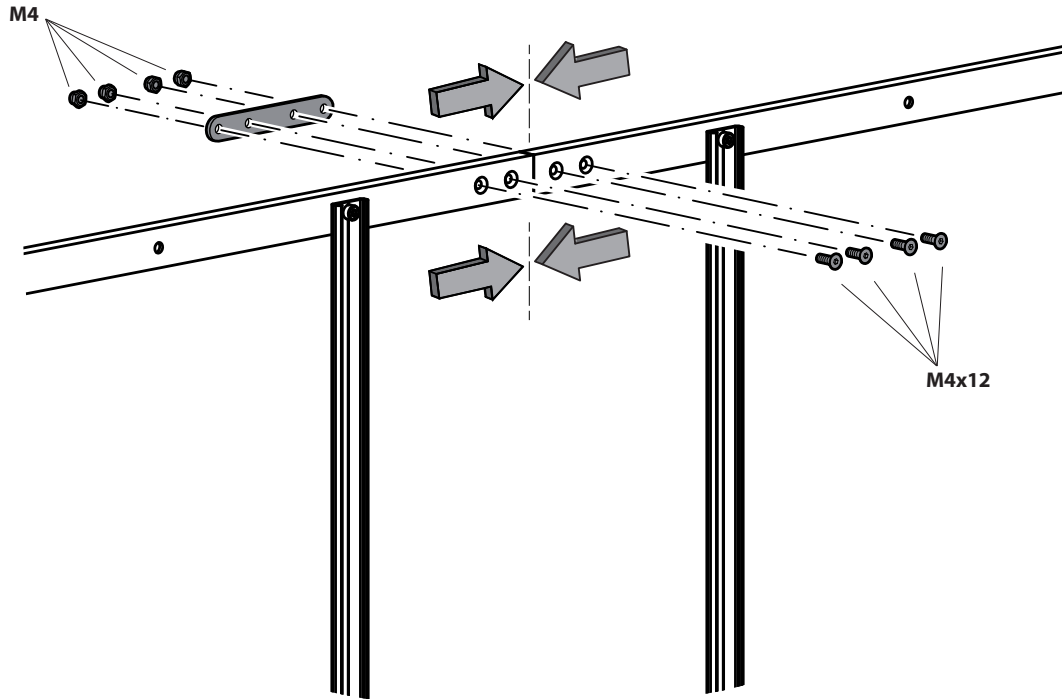

[www.bft-automation.com](http://www.bft-automation.com)

**BFT Spa**

Via Lago di Vico, 44 ITALY  
36015 Schio (VI)  
T +39 0445 69 65 11  
F +39 0445 69 65 22

**SPAIN**

**BFT GROUP ITALIBERICA DE  
AUTOMATISMOS SL**  
Camí de Can Bassa, 6, 08401  
Granollers, Barcelona, Spagna

**FRANCE**

**AUTOMATISMES BFT FRANCE SAS**  
50 rue jean zay  
69800 Saint-Priest, Francia

**GERMANY**

**BFT ANTRIEBSSYSTEME GMBH**  
Faber-Castell-Straße 29, 90522  
Oberasbach, Germania

**UNITED KINGDOM**

**BFT AUTOMATION UK LTD**  
Unit C2-C3 The Embankment Business  
Park, Vale Road Heaton Mersey Stockport  
Cheshire SK4 3GL United Kingdom

**BFT AUTOMATION (SOUTH) LTD**  
Enterprise House Murdock Road, Dorcan,  
Swindon, England, SN3 5HY

**PORTUGAL**

**BFT PORTUGAL SA**  
Urb. Pedrulha lote 9 - Apartado 8123,  
3025-248 Coimbra Portugal

**POLAND**

**BFT POLSKA SP ZOO**  
Marecka 49, 05-220 Zielonka, Polonia

**IRELAND**

**BFT AUTOMATION IRELAND**  
Unit D3 City Link Business Park, Old Naas  
Road, Dublin

**CROATIA**

**BFT ADRIA DOO**  
Obrovac 39, 51218, Dražice, Croazia

**CZECH REPUBLIC**

**BFT CZ SRO**  
Ustecka 533/9, 184 00 Praha 8,  
Czech

**TURKEY**

**BFT OTOMASYON KAPI**  
Şerifali Mahallesi, no, 34775  
Ümraniye/Istanbul, Turchia

**U.S.A.**

**BFT AMERICAS INC.**  
1200 S.W. 35th Avenue Suite B Boynton  
Beach FL 33426

**AUSTRALIA**

**BFT AUTOMATION AUSTRALIA PTY**  
29 Bentley St, Wetherill Park NSW  
2164, Australia

**EMIRATES**

**BFT MIDDLEEAST FZCO**  
FZS2 AA01 - PO BOX 262200, Jebel Ali Free  
Zone South Zone 2, Dubai - United Arab

**NEW ZEALAND**

**BFT AUTOMATION NEW ZEALAND**  
224/A Bush Road, Rosedale,  
Auckland, New Zealand