

PILLAR B 275/600.6C L

PILLAR B 275/600.6C L SD

PILLAR B 275/800.6C L

PILLAR B 275/800.6C L SD

PILLAR B O 275/800.6C L

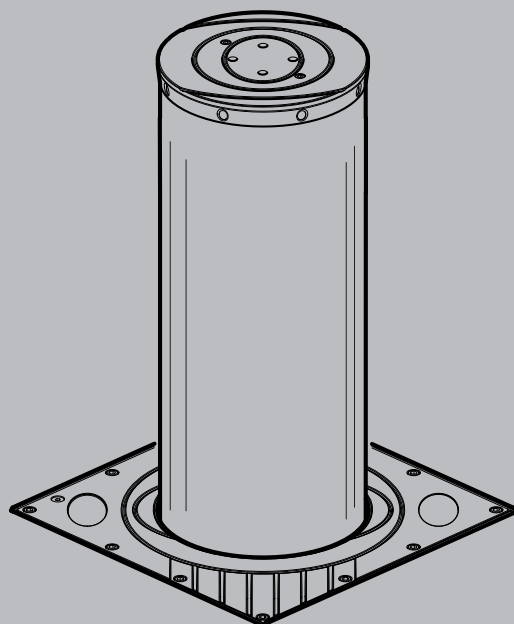

ISTRUZIONI PER INSTALLAZIONE USO E MANUTENZIONE
 INSTRUCTIONS FOR INSTALLATION, USE AND MAINTENANCE
 INSTRUCTIONS D'INSTALLATION ET D'ENTRETIEN
 INSTALLATIONS-, GEBRAUCHS- UND WARTUNGSANLEITUNGEN
 INSTRUCCIONES PARA LA INSTALACIÓN, EL USO Y EL MANTENIMIENTO

DISSUASORE AUTOMATICO
 AUTOMATIC BOLLARD
 BORNE AUTOMATIQUE
 AUTOMATISCHE PARKPLATZSPERREN
 DISUASOR AUTOMATICO

Attenzione! Leggere attentamente le "Avvertenze" all'interno! **Caution!** Read "Warnings" inside carefully!
Attention! Veuillez lire attentivement les Avertissements qui se trouvent à l'intérieur! **Achtung!** Bitte lesen Sie aufmerksam die „Hinweise“ im Inneren!
¡Atención! Leer atentamente las "Advertencias" en el interior!



AZIENDA CON
 SISTEMA DI GESTIONE
 CERTIFICATO DA DNV GL
 = ISO 9001 =
 = ISO 14001 =



GENERALITA'

Il dissuasore è la soluzione ideale per la gestione del traffico veicolare nel rispetto dei moderni canoni di arredo urbano. Può essere utilizzato per applicazioni di controlli accessi o per tutelare aree private con la massima sicurezza.

DATI TECNICI

Motore.....230V±10% 50÷60Hz 500W
Frequenza di lavoro.....3000/24h
Grado di protezione.....IP67
Centralina.....PERSEO CBD / PERSEO CBE
Temp. di esercizio.....-40 * +60 °C
Tempo di lavoro **

PILLAR B 275/600.6C L; PILLAR B 275/600.6C L SD
.....salita 4,8 s.; discesa 4,3s.
PILLAR B 275/800.6C L; PILLAR B 275/800.6C L SD; PILLAR B O 275/800.6C L

.....salita 6,1 s.; discesa 5,0 s.

Peso netto

PILLAR B 275/600.6C L; PILLAR B 275/600.6C L SD.....136 kg
PILLAR B 275/800.6C L; PILLAR B 275/800.6C L SD; PILLAR B O 275/800.6C L

.....149 kg

Peso lordo

PILLAR B 275/600.6C L; PILLAR B 275/600.6C L SD.....142 kg
PILLAR B 275/800.6C L; PILLAR B 275/800.6C L SD; PILLAR B O 275/800.6C L

.....157 kg

* Con riscaldatore integrato attivo (PERSEO CBE)

** A temperatura ambiente +25°C

GENERAL

The deterrent bollard is the ideal solution for managing vehicle traffic in compliance with modern urban furnishing requirements. It can be used to control entrances or to safeguard private areas in total safety.

TECHNICAL SPECIFICATIONS

Motor.....230V±10% 50÷60Hz 500W
Working frequency.....3000/24h
Protection level.....IP67
Control unit.....PERSEO CBD / PERSEO CBE
Working temperature.....-40 * +60 °C
Working time **

PILLAR B 275/600.6C L; PILLAR B 275/600.6C L SD
.....rise time: 4.8 s.; lowering time: 4.3s.
PILLAR B 275/800.6C L; PILLAR B 275/800.6C L SD; PILLAR B O 275/800.6C L

.....rise time: 6.1 s.; lowering time: 5.0 s.

Net weight

PILLAR B 275/600.6C L; PILLAR B 275/600.6C L SD.....136 kg
PILLAR B 275/800.6C L; PILLAR B 275/800.6C L SD; PILLAR B O 275/800.6C L

.....149 kg

Gross weight

PILLAR B 275/600.6C L; PILLAR B 275/600.6C L SD.....142 kg
PILLAR B 275/800.6C L; PILLAR B 275/800.6C L SD; PILLAR B O 275/800.6C L

.....157 kg

* With integrated heater active (PERSEO CBE)

** At +25°C ambient temperature

GENERALITES

La borne escamotable est la solution idéale pour contrôler le trafic routier selon les concepts modernes de mobilier urbain. Elle contrôle l'accès ou protège les espaces privés en toute sécurité.

DONNÉES TECHNIQUES

Moteur.....230V±10% 50÷60Hz 500W
Duree de l'operation.....3000/24h
Indice de protection.....IP67
Centrale.....PERSEO CBD / PERSEO CBE
Température d'exercice.....-40 * +60 °C
Temps de travail **

PILLAR B 275/600.6C L; PILLAR B 275/600.6C L SD
.....montée 4,8 s.; descente 4,3s.
PILLAR B 275/800.6C L; PILLAR B 275/800.6C L SD; PILLAR B O 275/800.6C L

.....montée 6,1 s.; descente 5,0 s.

2 - PILLAR B 275/600.6C L - PILLAR B 275/600.6C L SD - PILLAR B 275/800.6C L - PILLAR B 275/800.6C L SD - PILLAR B O 275/800.6C L

Poids net

PILLAR B 275/600.6C L; PILLAR B 275/600.6C L SD.....136 kg
PILLAR B 275/800.6C L; PILLAR B 275/800.6C L SD; PILLAR B O 275/800.6C L

.....149 kg

Poids brut

PILLAR B 275/600.6C L; PILLAR B 275/600.6C L SD.....142 kg
PILLAR B 275/800.6C L; PILLAR B 275/800.6C L SD; PILLAR B O 275/800.6C L

.....157 kg

* Avec chauffage intégré actif (PERSEO CBE)

** À la température ambiante +25°C

ALLGEMEINES

Der versenkbare Poller ist die ideale Lösung zum Verwalten des Straßenverkehrs unter Berücksichtigung der modernen Städteinrichtung. Der Poller kann unter Gewährleistung der maximalen Sicherheit für die Zufahrtskontrolle oder zum Absperren von Privatbereichen verwendet werden.

TECHNISCHE DATEN

Motor.....230V±10% 50÷60Hz 500W
Einsatzfrequenz.....3000/24h
Schutzgrad.....IP67
Steuergerät.....PERSEO CBD / PERSEO CBE
Betriebstemperatur.....-40 * +60 °C
Arbeitszeit **

PILLAR B 275/600.6C L; PILLAR B 275/600.6C L SD
.....4,8 s. Anstieg; 4,3s. Abstieg

PILLAR B 275/800.6C L; PILLAR B 275/800.6C L SD; PILLAR B O 275/800.6C L

.....6,1 s. Anstieg; 5,0 s. Abstieg

Reingewicht

PILLAR B 275/600.6C L; PILLAR B 275/600.6C L SD.....136 kg
PILLAR B 275/800.6C L; PILLAR B 275/800.6C L SD; PILLAR B O 275/800.6C L

.....149 kg

Bruttogewicht

PILLAR B 275/600.6C L; PILLAR B 275/600.6C L SD.....142 kg
PILLAR B 275/800.6C L; PILLAR B 275/800.6C L SD; PILLAR B O 275/800.6C L

.....157 kg

* Mit integrierter Heizung aktiv (PERSEO CBE)

** Zu Umgebungstemperatur +25°C

GENERALIDAD

El disuasor es la solución ideal para la gestión del tráfico de vehículos respetando los modernos cánones del mobiliario urbano. Se puede utilizar para aplicaciones de control de accesos o para proteger áreas privadas con la máxima seguridad.

DATOS TÉCNICOS

Motor.....230V±10% 50÷60Hz 500W
Frecuencia de trabajo.....3000/24h
Grado de protección.....IP67
Central.....PERSEO CBD / PERSEO CBE
Temperatura de operación.....-40 * +60 °C
Tiempo de trabajo **

PILLAR B 275/600.6C L; PILLAR B 275/600.6C L SD
.....salida 4,8 s.; bajata 4,3s.

PILLAR B 275/800.6C L; PILLAR B 275/800.6C L SD; PILLAR B O 275/800.6C L

.....salida 6,1 s.; bajata 5,0 s.

Peso neto

PILLAR B 275/600.6C L; PILLAR B 275/600.6C L SD.....136 kg
PILLAR B 275/800.6C L; PILLAR B 275/800.6C L SD; PILLAR B O 275/800.6C L

.....149 kg

Peso bruto

PILLAR B 275/600.6C L; PILLAR B 275/600.6C L SD.....142 kg

PILLAR B 275/800.6C L; PILLAR B 275/800.6C L SD; PILLAR B O 275/800.6C L

.....157 kg

* Con calentador integrado activo (PERSEO CBE)

** A temperatura ambiente +25°C

TUTTE LE DIMENSIONI IN mm / ALL DIMENSIONS IN mm / TOUTES LES DIMENSIONS EN MM / ALLE ABMESSUNGEN IN mm / TODAS LAS DIMENSIONES EN mm

A **DIMENSIONI D'INGOMBRO, OVERALL SIZE DIMENSIONS, DIMENSIONS D'ENCOMBREMENT, RAUMBEDARF-ABMESSUNGEN, DIMENSIONES MÁXIMAS**

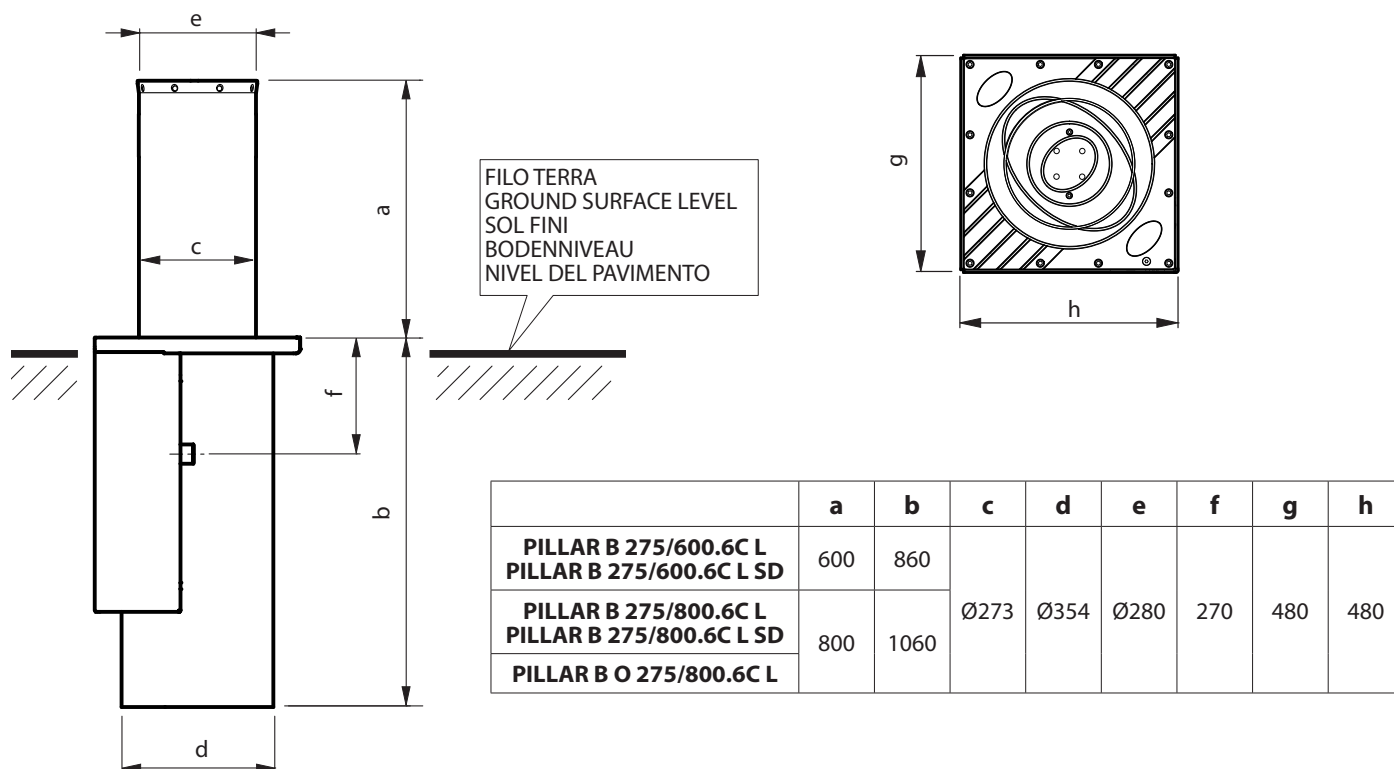

B **DISPOSIZIONE, LAYOUT, DISPOSITION, LAYOUT, DISPOSICIÓN**

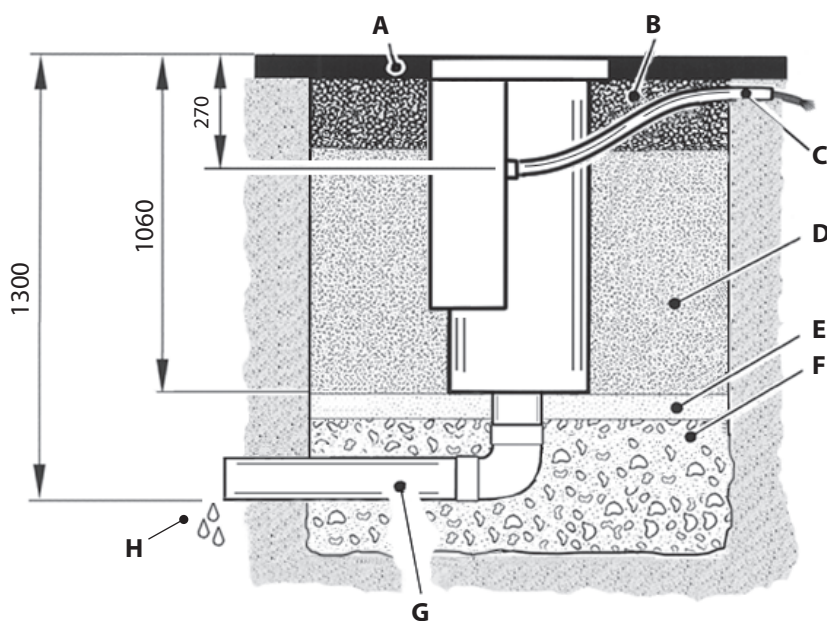

A	Asfalto / Road surface / Asphalte / Asphalt / Asfalto
B	Cemento / Cement / Ciment / Zement / Cemento
C	Guaina Ø50 / Sheathing Ø50 / Gaine Ø50 / Anschluss Ø50 / Vaina Ø50
D	Sabbia compatta / Compact sand / Sable compact / Verdichtetsand / Arena compacta
E	Sabbia fine / Fine sand / Sable fin / Feiner sand / Arena fina
F	Ghiaia / Pebble gravel / Gravier / Kies / Gravilla
G	Drenaggio Ø125 / Drainage Ø125 / Drainage Ø125 / Drainage Ø125 / Drenaje Ø125
H	Allacciamento alla rete fognaria / Connection to the sewer network / Raccordement au tout-à-l'égout / Anschluss an das Abwassernetz / Conexión a la red de alcantarillado

C

NOTA CAVI, WIRING NOTE, BRANCHEMENTS, BEMERKUNG ZU DEN KABEL ANSCHLÜSSEN, NOTA CABLES

D812167 00550_11

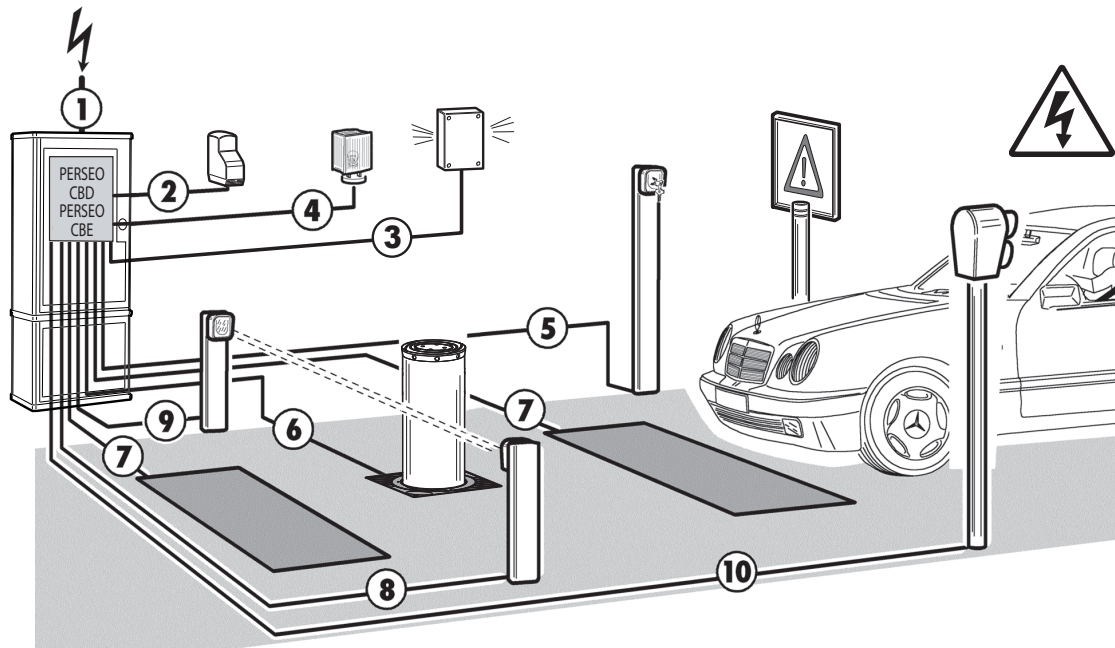

①	Linea Monofase / Single-phase line / Ligne monophasée / Einphasenleitung / Linea monofàsica	H05VV 2 x 1,5 + T
②	Ricevitore / Receiver / Récepteur / Empfänger / Receptor	4 x 0,5
③	SOS	4 x 0,5
④	Lampeggiante / Flasher / Clignotant / Blinkleuchte / Indicador intermitente	2 x 0,5
⑤	Selettore a chiave / Key selector / Sélecteur à clé / Schlüsselschalter / Selector de llave	2 x 0,5
⑥	PILLAR B 275/600.6C L PILLAR B 275/600.6C L SD PILLAR B 275/800.6C L PILLAR B 275/800.6C L SD PILLAR B O 275/800.6C L	Cavo in dotazione Cable supplied by us Cable fourni en dotation Kabel beige stellt Cable incluido
⑦	Rivelatore magnetico / Magnetic detector / Détecteur magnétique / Magnetdetektor / Detector magnético	Cavo intrecciato Twisted cable Torsade de conducteurs Verdrilltes Kabel Cable trenzado
⑧	Fotocellula trasmittente / Transmitter photocell / Photocellule émettrice / Senderfotozelle / Fotocèlula transmisor	2 x 0,5
⑨	Fotocellula ricevitore / Receiver photocell / Photocellule réceptrice / Empfängerfotozelle - Fotocèlula receptor	4 x 0,5
⑩	Semaforo / Traffic light / Feu tricolore / Ampel / Semáforo	3 x 0,5 + T

D

FONDAZIONE, FOUNDATION, FONDATION, FUNDAMENT, FOSA

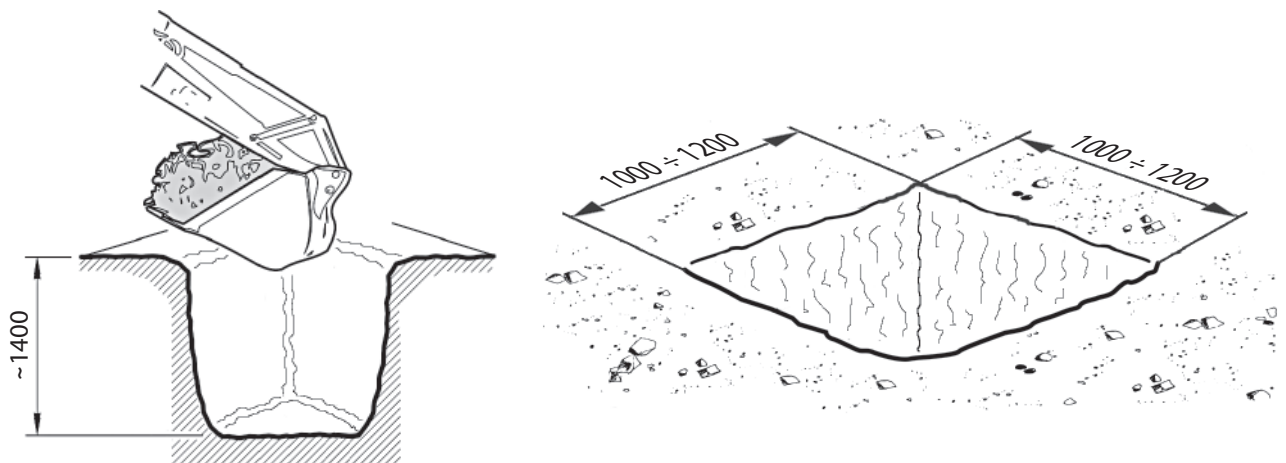

4 - PILLAR B 275/600.6C L - PILLAR B 275/600.6C L SD - PILLAR B 275/800.6C L - PILLAR B 275/800.6C L SD - PILLAR B O 275/800.6C L

E DRENAGGIO, DRAINAGE, DRAINAGE, DRAINAGE, DRENAJE

IT Assicurarsi che il terreno abbia un buon assorbimento d'acqua immettendo circa 40 litri d'acqua e verificando che lo svuotamento avvenga in meno di 30 minuti; in caso contrario realizzare il drenaggio delle acque tramite tubazioni da collegare ad ogni singola cassaforma e raccordate ad un tubo di drenaggio, oppure ad un pozzetto dotato di un sistema di svuotamento dell'acqua.

EN Ensure that the soil has a adequate water absorption by entering about 40 liters of water and checking that the emptying takes place in less than 30 minutes; otherwise realize the drainage of water through pipes connected to every single manhole and connected to a drainage pipe, or a collecting sump with a drainage system of water.

FR Avant de réaliser le coffrage, il faut vérifier la perméabilité du sol: le drainage minimum doit être de 80 litres/heure. Si l'évacuation de l'eau est trop faible, il est fortement recommandé soit de le raccorder à un tuyau de drainage, soit de construire un puit perdu.

DE Sicherstellen, dass das Gelände eine gute Wasseraufnahme gewährleistet, indem ca. 40 Liter Wasser eingefüllt und kontrolliert wird, dass das Wasser in weniger als 30 Minuten absickert. Andernfalls muss die Ableitung des Wassers anhand von Rohren erfolgen, an ein Abflussrohr anschließenoder mit einem mit Entwässerungssystem ausgestatteten Schacht zu verbinden sind.

ES Asegúrase de que el suelo tenga un buen absorbimiento del agua de aproximadamente 40 litros de agua, controlar que el vaciado sea efectuado en menos de 30 minutos; de lo contrario realice el drenaje a través de los tubos que deben ser conectados a cada encofrado del bolardo y a su vez conectado a una tubería de drenaje o a un buen sistema de drenaje.

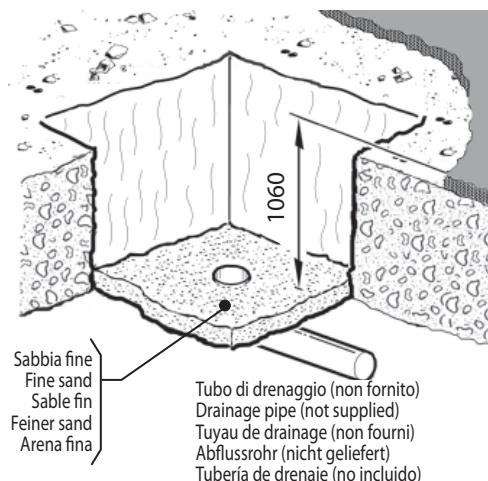

F POSIZIONARE IL DISSUASORE, FIT THE BOLLARD, POSITIONNER LA BORNE, DEN POLLER EINSETZEN, COLOCAR EL POSTE

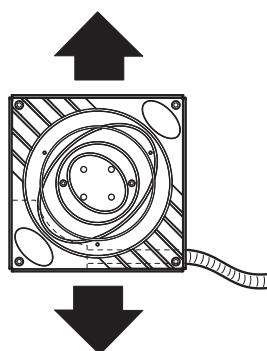

Senso di marcia
Running direction
Sens de marche
Fahrtrichtung
Dirección de marcha

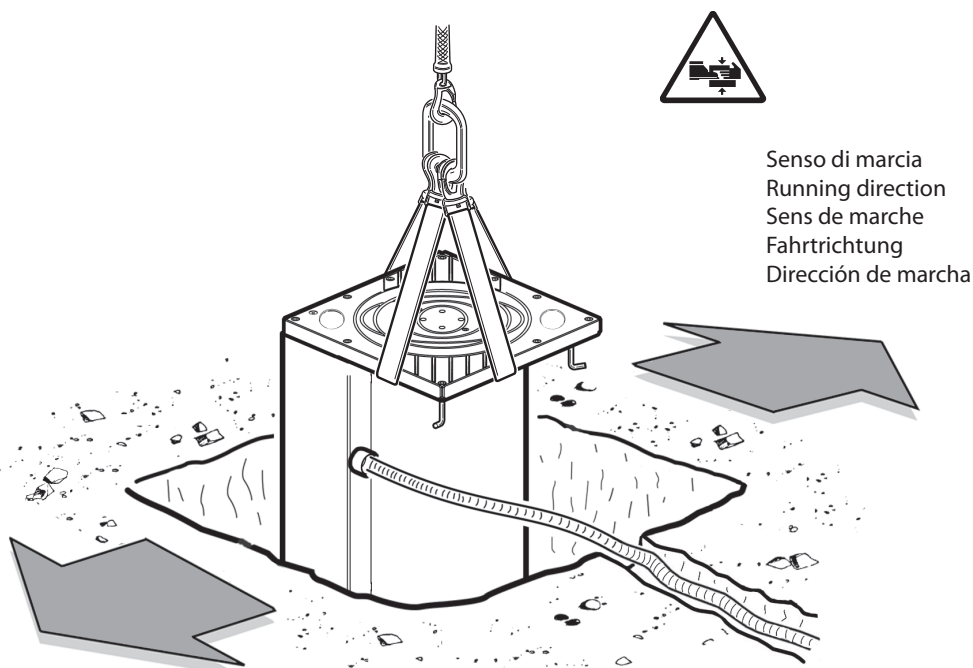

Senso di marcia
Running direction
Sens de marche
Fahrtrichtung
Dirección de marcha

- G** LIVELLARE COL PIANO STRADALE, LEVEL WITH THE ROAD SURFACE, NIVELER SUR LE PLAN DE LA ROUTE, MIT DER STRASSENEBENE AUSRICHTEN, NIVELAR CON EL NIVEL DE LA CALZADA

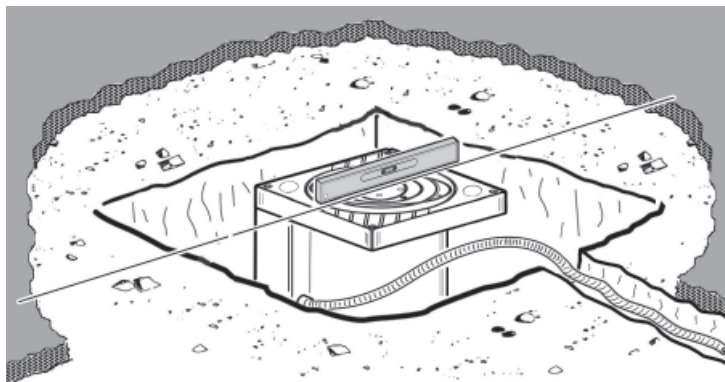

- H** RIEMPIRE DI SABBIA FINO A ~200 MM DAL PIANO STRADALE, FILL WITH SAND TO ~200 MM FROM THE ROAD SURFACE, REMPLIR AVEC DU SABLE JUSQU'À ~200MM DU PLAN DE LA ROUTE, BIS AUF ~200 MM VON DER STRASSENEBENE MIT SAND BEFUELLEN, LLENAR DE ARENA HASTA ~200 MM DEL NIVEL DE LA CALZADA

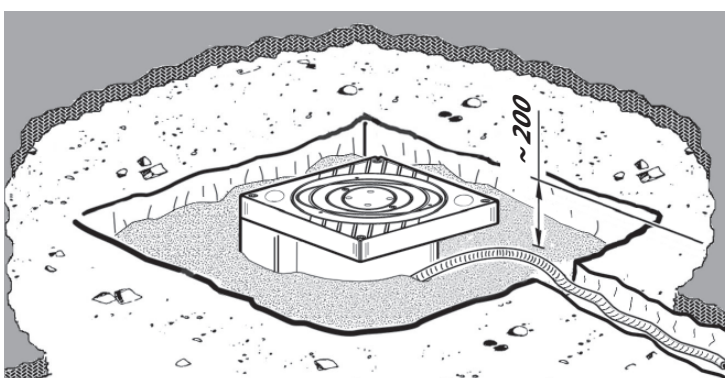

- I** POSARE LA RETE ELETTRISALDATA E RIEMPIRE DI CEMENTO, LAY THE ELECTROWELDED MESH AND FILL WITH CONCRETE, POSER LA GRILLE ELECTRO-SOUDÉE ET REMPLIR DE CIMENT, DIE BAUSTAHLMATTE VERLEGEN UND FÜLLEN SIE MIT ZEMENT, COLOCAR LA REJILLA ELECTROSOLDADA E Y LLENAR CON CEMENTO

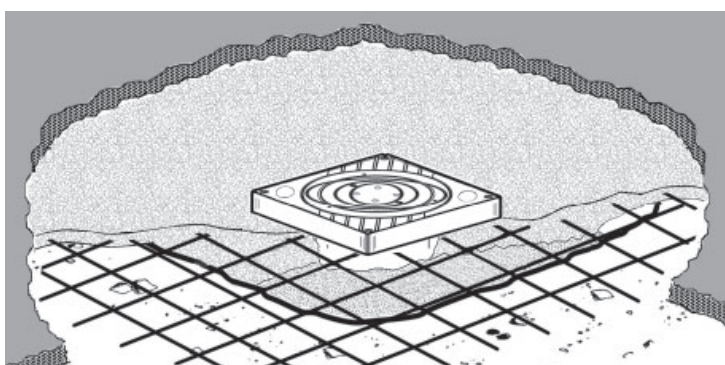

- L** COMPLETARE LA PAVIMENTAZIONE, FLOORING COMPLETION, COMPLETER LE SOL, DEN BODENBELAG FERTIGSTELLEN, TERMINAR EL PAVIMENTO

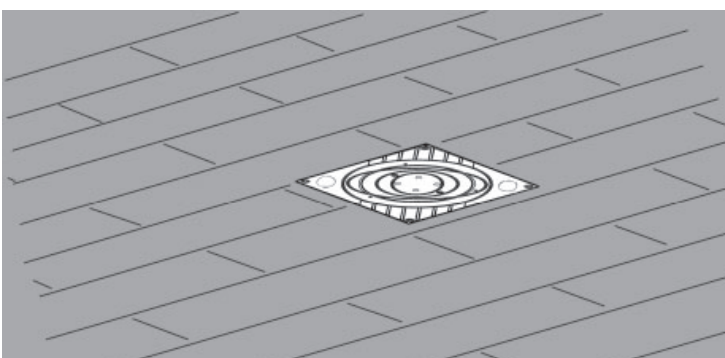

M

COLLEGAMENTI ELETTRICI, ELECTRICAL CONNECTIONS, BRANCHEMENTS ELECTRIQUES, ELEKTRISCHE ANSCHLÜSSE, CONEXIONES ELÉCTRICAS

1

PERSEO CBD



NON DISPONIBILE PER PILLAR B O 275/800.6C L
 NOT AVAILABLE FOR PILLAR B O 275/800.6C L
 NON DISPONIBLE POUR PILLAR B O 275/800.6C L
 NICHT VERFÜGBAR FÜR PILLAR B O 275/800.6C L
 NO DISPONIBLE PARA PILLAR B O 275/800.6C L

Isolare i cavi non utilizzati
 Isolate unused cable
 Isoler les conducteurs inutilisés
 Isolieren Sie das Kabel unbenutzte
 Aísle el cable no utilizado

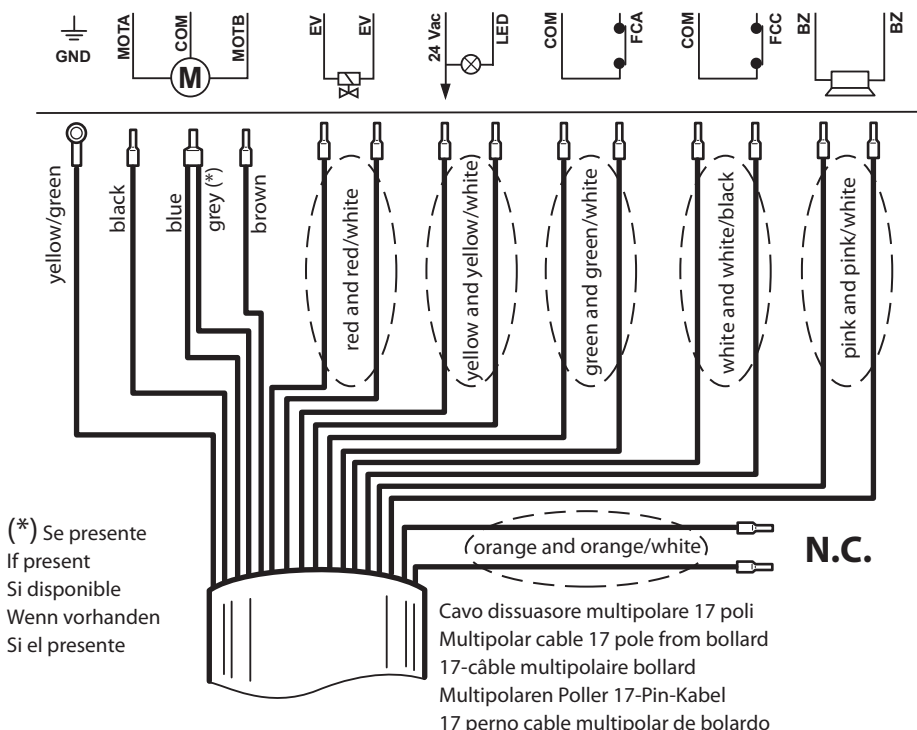

(* Se presente
 If present
 Si disponible
 Wenn vorhanden
 Si el presente

Cavo dissuasore multipolare 17 poli
 Multipolar cable 17 pole from bollard
 17-câble multipolaire bollard
 Multipolaren Poller 17-Pin-Kabel
 17 perno cable multipolar de bolardo

PERSEO CBD

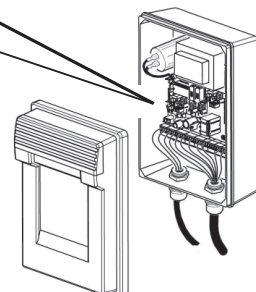

Consultare il manuale d'installazione e uso della centralina PERSEO CBD.
 Consult the PERSEO CBD control unit's installation and operating manual.
 Consulter le manuel d'installation et d'utilisation de la centrale PERSEO CBD.
 Die Installations und Bedienungsanleitungen der Steuereinheit PERSEO CBD nachschlagen.
 Consultar el manual de instalación y uso de la centralita PERSEO CBD.

2

PERSEO CBE

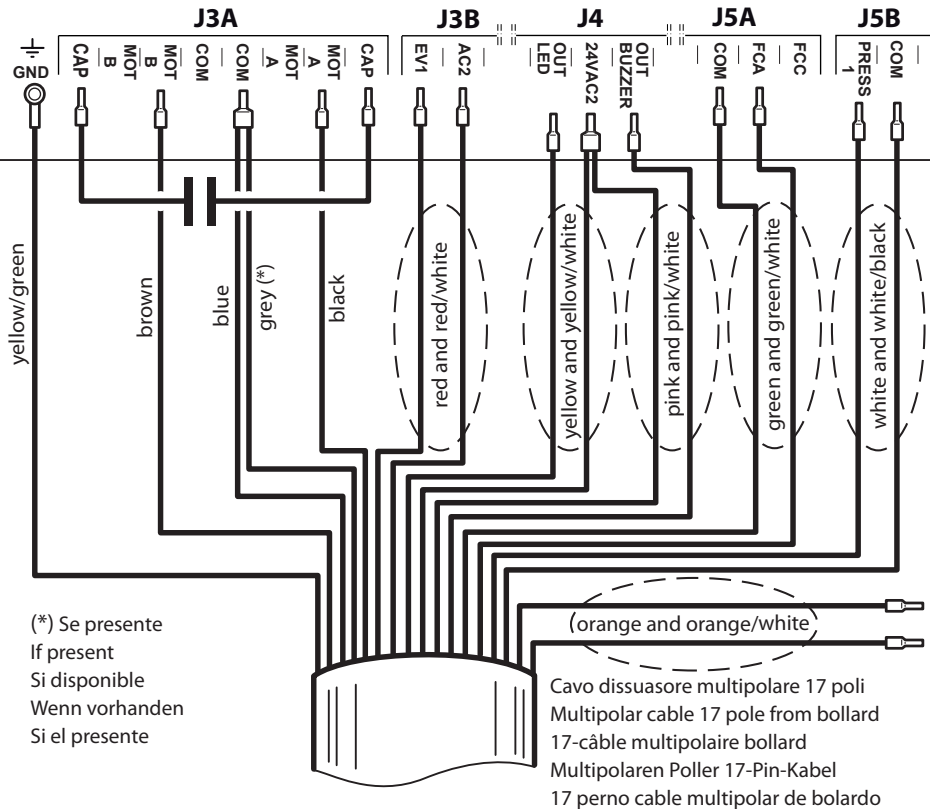

(* Se presente
 If present
 Si disponible
 Wenn vorhanden
 Si el presente

Cavo dissuasore multipolare 17 poli
 Multipolar cable 17 pole from bollard
 17-câble multipolaire bollard
 Multipolaren Poller 17-Pin-Kabel
 17 perno cable multipolar de bolardo

PERSEO CBE

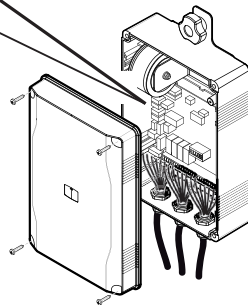

Antitheft or FCC upper limit switch (optional)

Isolare i cavi non utilizzati
 Isolate unused cable
 Isoler les conducteurs inutilisés
 Isolieren Sie das Kabel unbenutzte
 Aísle el cable no utilizado

Consultare il manuale d'installazione e uso della centralina PERSEO CBE.
 Consult the PERSEO CBE control unit's installation and operating manual.
 Consulter le manuel d'installation et d'utilisation de la centrale PERSEO CBE.
 Die Installations und Bedienungsanleitungen der Steuereinheit PERSEO CBE nachschlagen.
 Consultar el manual de instalación y uso de la centralita PERSEO CBE.

N SBLOCCO D'EMERGENZA, HAND MANOEUVRE, MANOEUVRE MANUELLE, MANUELLE BETÄTIGUNG, MANIOBRA MANUAL

1 VERSIONE STANDARD / STANDARD VERSION / VERSION STANDARD / STANDARDVERSION / VERSIÓN ESTÁNDAR

Interrompendo l'alimentazione elettrica il dissuasore scende spontaneamente.

The deterrent bollard lowers spontaneously when you disconnect the power supply.

Lorsque l'alimentation électrique est coupée, la borne s'abaisse automatiquement.

Bei Unterbrechen der Stromversorgung wird der Poller automatisch versenkt.

Cortando la alimentación eléctrica la columna baja espontáneamente.

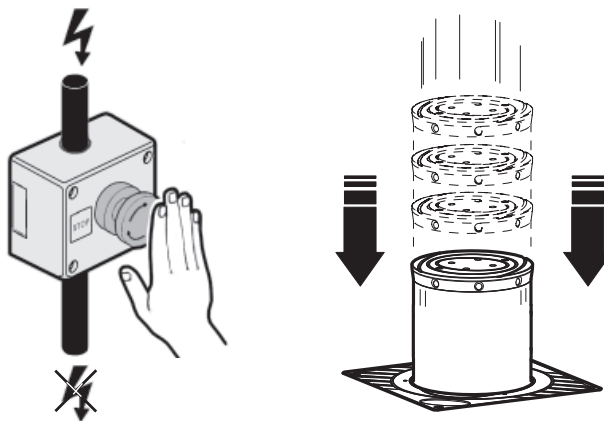

2 VERSIONE SD / SD VERSION / VERSION SD / SD VERSION / VERSIÓN SD

Interrompendo l'alimentazione elettrica il dissuasore mantiene il varco chiuso.

If the power supply is cut off, the bollard keeps the gateway closed.

En coupant l'alimentation électrique la borne maintient le passage fermé.

Wenn die Stromzufuhr unterbrochen wird, hält der Poller den Durchgang geschlossen.

Interrumpiendo la alimentación eléctrica, el bolardo mantiene el paso cerrado.



NON DISPONIBILE PER PILLAR B O 275/800.6C L
NOT AVAILABLE FOR PILLAR B O 275/800.6C L
NON DISPONIBILE POUR PILLAR B O 275/800.6C L
NICHT VERFÜGBAR FÜR PILLAR B O 275/800.6C L
NO DISPONIBLE PARA PILLAR B O 275/800.6C L

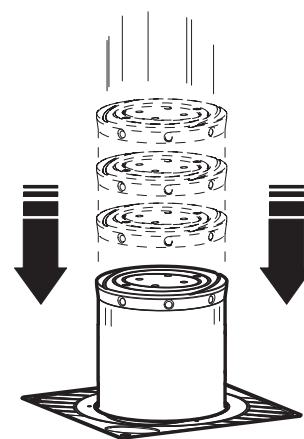
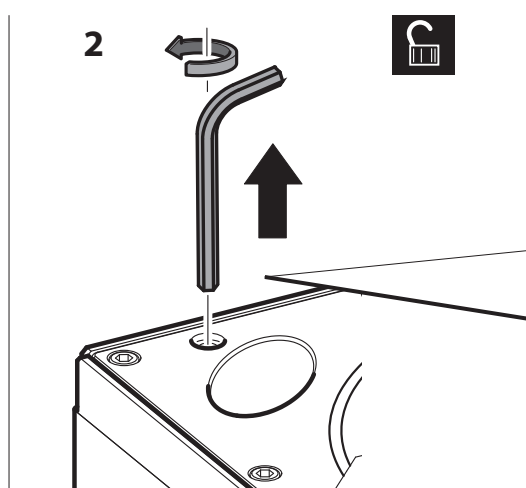
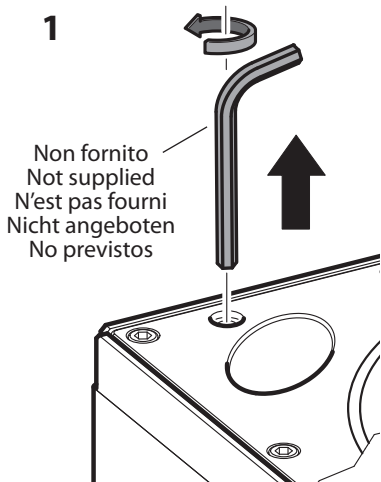

IT Il mantenimento del varco chiuso in assenza di alimentazione è garantito per un tempo massimo di 48h, trascorso questo tempo può verificarsi un lento ma progressivo abbassamento del dissuasore.

EN The closure of the gateway in the absence of power supply is guaranteed for a maximum time of 48 hours, then a slow, progressive lowering of the bollard can occur.

FR Le maintien du passage fermé en l'absence d'alimentation est garanti pour une durée maximale de 48h, une fois ce délai écoulé il peut se produire un abaissement lent mais progressif de la borne.

DE Der geschlossene Durchgang ist bei Stromausfall für maximal 48 Stunden gewährleistet, danach kann es zu einem langsamen, aber fortschreitenden Absenken des Pollers kommen.

ES El mantenimiento del paso cerrado en ausencia de alimentación está garantizado durante un tiempo máximo de 48 h, después del cual puede producirse una lenta pero progresiva bajada del bolardo.

REGISTRO DI MANUTENZIONE

MAINTENANCE LOG

REGISTRE DES OPÉRATIONS D'ENTRETIEN

INSTANDHALTUNGSPLAN

RESISTRO DE MANTENIMIENTO

Dati impianto / Installation data

Installatore Installer	
Cliente Customer	
Matricola Serial number	
Data installazione Installation date	
Data attivazione Activation date	
Luogo Location	

Dati manutenzione / Maintenance date

Nr.	Data • Date	Descrizione intervento • Intervention description	Firma • Signature
1			Tecnico • Technician
			Cliente • Customer
2			Tecnico • Technician
			Cliente • Customer
3			Tecnico • Technician
			Cliente • Customer
4			Tecnico • Technician
			Cliente • Customer
5			Tecnico • Technician
			Cliente • Customer
6			Tecnico • Technician
			Cliente • Customer
7			Tecnico • Technician
			Cliente • Customer
8			Tecnico • Technician
			Cliente • Customer

Nr.	Data • Date	Descrizione intervento • Intervention description	Firma • Signature
9			Tecnico • <i>Technician</i>
			Cliente • <i>Customer</i>
10			Tecnico • <i>Technician</i>
			Cliente • <i>Customer</i>
11			Tecnico • <i>Technician</i>
			Cliente • <i>Customer</i>
12			Tecnico • <i>Technician</i>
			Cliente • <i>Customer</i>
13			Tecnico • <i>Technician</i>
			Cliente • <i>Customer</i>
14			Tecnico • <i>Technician</i>
			Cliente • <i>Customer</i>
15			Tecnico • <i>Technician</i>
			Cliente • <i>Customer</i>
16			Tecnico • <i>Technician</i>
			Cliente • <i>Customer</i>
17			Tecnico • <i>Technician</i>
			Cliente • <i>Customer</i>
18			Tecnico • <i>Technician</i>
			Cliente • <i>Customer</i>
19			Tecnico • <i>Technician</i>
			Cliente • <i>Customer</i>
20			Tecnico • <i>Technician</i>
			Cliente • <i>Customer</i>
21			Tecnico • <i>Technician</i>
			Cliente • <i>Customer</i>

INSTALLATORE
INSTALLER
INSTALLATEUR
INSTALLATEUR
INSTALATOR

DATA
DATE
DATE
DATUM
FECHA



www.bft-automation.com

BFT Spa

Via Lago di Vico, 44 ITALY
36015 Schio (VI)
T +39 0445 69 65 11
F +39 0445 69 65 22

SPAIN

BFT GROUP ITALIBERICA DE AUTOMATISMOS SL
Camí de Can Bassa, 6, 08401 Granollers, Barcelona, Spagna

FRANCE

AUTOMATISMES BFT FRANCE SAS
50 rue jean zay
69800 Saint-Priest, Francia

GERMANY

BFT ANTRIEBSSYSTEME GMBH
Faber-Castell-Straße 29, 90522 Oberasbach, Germania

UNITED KINGDOM

BFT AUTOMATION UK LTD
Unit C2-C3 The Embankment Business Park, Vale Road Heaton Mersey Stockport Cheshire SK4 3GL United Kingdom

BFT AUTOMATION (SOUTH) LTD
Enterprise House Murdock Road, Dorcan, Swindon, England, SN3 5HY

PORTUGAL

BFT PORTUGAL SA
Urb. Pedrulha lote 9 - Apartado 8123, 3025-248 Coimbra Portugal

POLAND

BFT POLSKA SP ZOO
Marecka 49, 05-220 Zielonka, Polonia

IRELAND

BFT AUTOMATION IRELAND
Unit D3 City Link Business Park, Old Naas Road, Dublin

CROATIA

BFT ADRIA DOO
Obrovac 39, 51218, Dražice, Croazia

CZECH REPUBLIC

BFT CZ SRO
Ustecka 533/9, 184 00 Praha 8, Czech

TURKEY

BFT OTOMASYON KAPI
Şerifali Mahallesi, no, 34775 Ümraniye/Istanbul, Turchia

U.S.A.

BFT AMERICAS INC.
1200 S.W. 35th Avenue Suite B Boynton Beach FL 33426

AUSTRALIA

BFT AUTOMATION AUSTRALIA PTY
29 Bentley St, Wetherill Park NSW 2164, Australia

EMIRATES

BFT MIDDLEEAST FZCO
FZS2 AA01 -PO BOX 262200, Jebel Ali Free Zone South Zone 2, Dubai - United Arab

NEW ZEALAND

BFT AUTOMATION NEW ZEALAND
224/A Bush Road, Rosedale, Auckland, New Zealand