

STOPPY B 115/500

STOPPY B 200/700

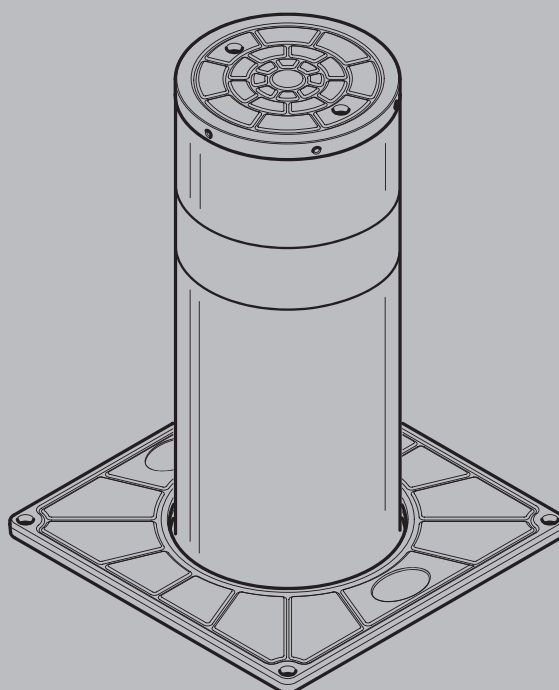

ISTRUZIONI PER INSTALLAZIONE USO E MANUTENZIONE
 INSTRUCTIONS FOR INSTALLATION, USE AND MAINTENANCE
 INSTRUCTIONS D'INSTALLATION ET D'ENTRETIEN
 INSTALLATIONS-, GEBRAUCHS- UND WARTUNGSANLEITUNGEN
 INSTRUCCIONES PARA LA INSTALACIÓN, EL USO Y EL MANTENIMIENTO

DISSUASORE AUTOMATICO
 AUTOMATIC BOLLARD
 BORNE AUTOMATIQUE
 AUTOMATISCHE PARKPLATZSPERREN
 DISUASOR AUTOMATICO

Attenzione! Leggere attentamente le "Avvertenze" all'interno! **Caution!** Read "Warnings" inside carefully!
Attention! Veuillez lire attentivement les Avertissements qui se trouvent à l'intérieur! **Achtung!** Bitte lesen Sie aufmerksam die „Hinweise“ im Inneren!
¡Atención! Leer atentamente las "Advertencias" en el interior!



AZIENDA CON
 SISTEMA DI GESTIONE
 CERTIFICATO DA DNV GL
 = ISO 9001 =
 = ISO 14001 =



GENERALITA'

Il dissuasore è la soluzione ideale per la gestione del traffico veicolare nel rispetto dei moderni canoni di arredo urbano. Può essere utilizzato per applicazioni di controlli accessi o per tutelare aree private con la massima sicurezza.

DATI TECNICI

Motore.....	230V±10% 50÷60Hz 300W 10uF 1,4 A
Frequenza di lavoro.....	500/24h
Grado di protezione.....	IP67
Centralina.....	PERSEO CBD / PERSEO CBE
Temp. di esercizio.....	-40 ** +60 °C
Tempo di lavoro.....	6 s. *** (STOPPY B 115/500)
	9 s. *** (STOPPY B 200/700)
Peso netto.....	57 kg (STOPPY B 115/500)
	103 kg (STOPPY B 200/700)
Peso lordo.....	60 kg (STOPPY B 115/500)
	115 kg (STOPPY B 200/700)

** Con riscaldatore integrato attivo (PERSEO CBE)

*** A temperatura ambiente +25°C

GENERAL

The deterrent bollard is the ideal solution for managing vehicle traffic in compliance with modern urban furnishing requirements. It can be used to control entrances or to safeguard private areas in total safety.

TECHNICAL SPECIFICATIONS

Motor.....	230V±10% 50÷60Hz 300W 10uF 1,4 A
Working frequency.....	500/24h
Protection level.....	IP67
Control unit.....	PERSEO CBD / PERSEO CBE
Working temperature.....	-40 ** +60 °C
Working time.....	6 s. *** (STOPPY B 115/500)
	9 s. *** (STOPPY B 200/700)
Net weight.....	57 kg (STOPPY B 115/500)
	103 kg (STOPPY B 200/700)
Gross weight.....	60 kg (STOPPY B 115/500)
	115 kg (STOPPY B 200/700)

** With integrated heater active (PERSEO CBE)

*** At 25 °C ambient temperature

GENERALITES

La borne escamotable est la solution idéale pour contrôler le trafic routier selon les concepts modernes de mobilier urbain. Elle contrôle l'accès ou protège les espaces privés en toute sécurité.

DONNÉES TECHNIQUES

Moteur.....	230V±10% 50÷60Hz 300W 10uF 1,4 A
Duree de l'operation.....	500/24h
Indice de protection.....	IP67
Centrale.....	PERSEO CBD / PERSEO CBE
Température d'exercice.....	-40 ** +60 °C
Temps de travail.....	6 s. *** (STOPPY B 115/500)
	9 s. *** (STOPPY B 200/700)
Poids net.....	57 kg (STOPPY B 115/500)
	103 kg (STOPPY B 200/700)
Poids brut.....	60 kg (STOPPY B 115/500)
	115 kg (STOPPY B 200/700)

** Avec réchauffeur incorporé actif (PERSEO CBE)

*** À la température ambiante +25°C

ALLGEMEINES

Der versenkbare Poller ist die ideale Lösung zum Verwalten des Straßenverkehrs unter Berücksichtigung der modernen Stadteinrichtung. Der Poller kann unter Gewährleistung der maximalen Sicherheit für die Zufahrtskontrolle oder zum Absperren von Privatbereichen verwendet werden.

TECHNISCHE DATEN

Motor.....	230V±10% 50÷60Hz 300W 10uF 1,4 A
Einsatzfrequenz.....	500/24h
Schutzgrad.....	IP67
Steuergerät.....	PERSEO CBD / PERSEO CBE
Betriebstemperatur.....	-40 ** +60 °C
Arbeitszeit.....	6 s. *** (STOPPY B 115/500)
	9 s. *** (STOPPY B 200/700)
Reingewicht.....	57 kg (STOPPY B 115/500)
	103 kg (STOPPY B 200/700)
Bruttogewicht.....	60 kg (STOPPY B 115-500)
	115 kg (STOPPY B 200/700)

** Mit aktiver integrierter Heizung (PERSEO CBE)

*** Bei Umgebungstemperatur +25°C

GENERALIDAD

El disuasor es la solución ideal para la gestión del tráfico de vehículos respetando los modernos cánones del mobiliario urbano. Se puede utilizar para aplicaciones de control de accesos o para proteger áreas privadas con la máxima seguridad.

DATOS TÉCNICOS

Motor.....	230V±10% 50÷60Hz 300W 10uF 1,4 A
Frecuencia de trabajo.....	500/24h
Grado de protección.....	IP67
Central.....	PERSEO CBD / PERSEO CBE
Temperatura de operación.....	-40 ** +60 °C
Tiempo de trabajo.....	6 s. *** (STOPPY B 115/500)
	9 s. *** (STOPPY B 200/700)
Peso neto.....	57 kg (STOPPY B 115/500)
	103 kg (STOPPY B 200/700)
Peso bruto.....	60 kg (STOPPY B 115/500)
	115 kg (STOPPY B 200/700)

** Con calefactor integrado activo (PERSEO CBE)

*** A temperatura ambiente +25°C

A DIMENSIONI D'INGOMBRO, OVERALL SIZE DIMENSIONS, DIMENSIONS D'ENCOMBREMENT, RAUMBEDARF-ABMESSUNGEN, DIMENSIONES MÁXIMAS

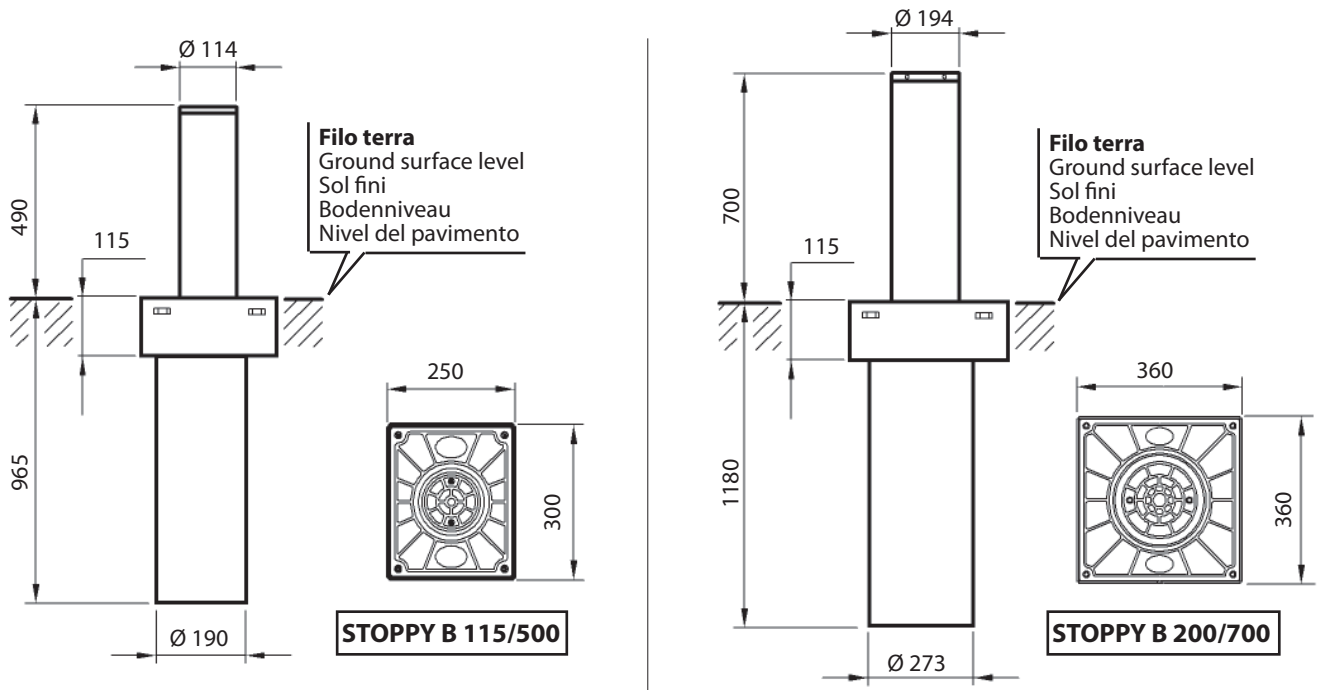

B NOTA CAVI, WIRING NOTE, BRANCHEMENTS, BEMERKUNG ZU DEN KABEL ANSCHLÜSSEN, NOTA CABLES

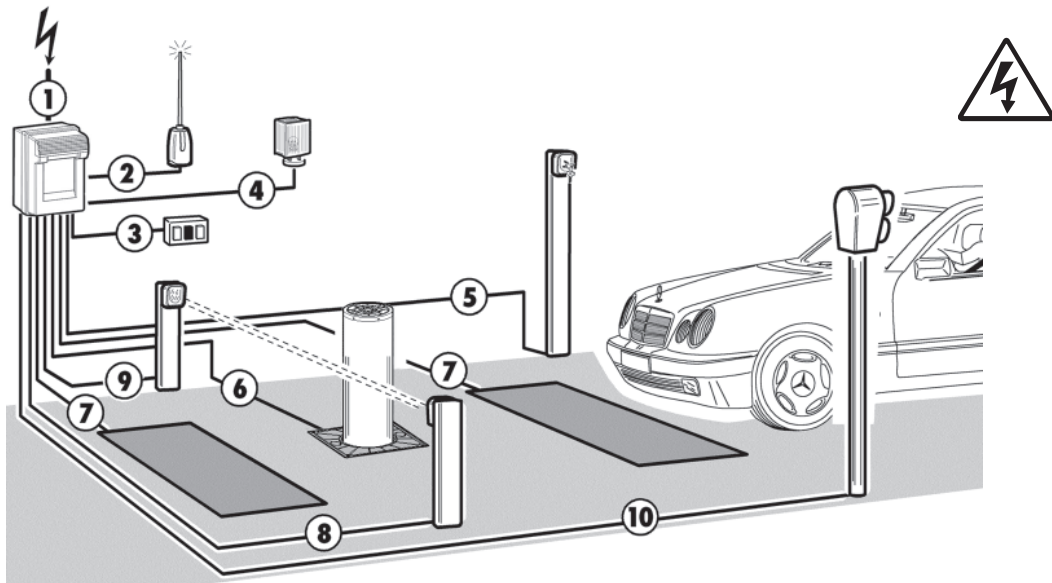

①	Linea Monofase - Single-phase line - Ligne monophasée - Einphasenleitung - Linea monofásica	H05VV 2 x 1,5 + T
②	Ricevitore - Receiver - Récepteur - Empfänger - Receptor	4 x 0,5
③	Pulsantiera - Push button panel - Console - Druckknopftafel - Botonera	4 x 0,5
④	Lampeggiante - Flasher - Clignotant - Blinkleuchte - Indicador intermitente	2 x 0,5
⑤	Selettore a chiave - Key selector - Sélecteur à clé - Schlüsselschalter - Selector de llave	2 x 0,5
⑥	STOPPY B 115/500 STOPPY B 200/700	Cavi in dotazione 10m Cables supplied by us 10m Cables fournis en dotation 10m Kabel beigestellt 10m Cables incluido 10m
⑦	Rivelatore magnetico - Magnetic detector - Détecteur magnétique - Magnetdetektor - Detector magnético	RG58
⑧	Fotocellula trasmettitore - Transmitter photocell - Photocellule émettrice - Senderfotozelle - Fotocèlula transmisor	2 x 0,5
⑨	Fotocellula ricevitore - Receiver photocell - Photocellule réceptrice - Empfängerfotozelle - Fotocèlula receptor	4 x 0,5
⑩	Semaforo - Traffic light - Feu tricolore - Ampel - Semáforo	3 x 0,5 + T

C DISPOSIZIONE, LAYOUT, DISPOSITION, LAYOUT, DISPOSICIÓN

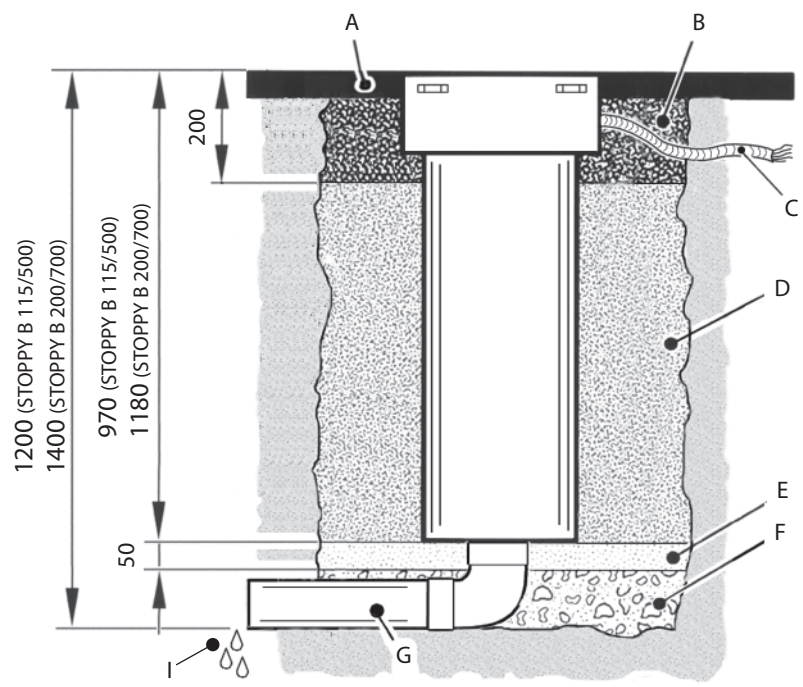

A	Asfalto - Road surface - Asphalte - Asphalt - Asfalto
B	Cemento - Cement - Ciment - Zement - Cemento
C	Guaina Ø50 - Sheathing Ø50 - Gaine Ø50 - Anschluss Ø50 - Vaina Ø50
D	Sabbia compatta - Compact sand - Sable compact - Verdichtetsand - Arena compacta
E	Sabbia fine - Fine sand - Sable fin - Feiner sand - Arena fina
F	Ghiaia - Pebble gravel - Gravier - Kies - Gravilla
G	Drenaggio Ø125 - Drainage Ø125 - Drainage Ø125 - Drainage Ø125 - Drenaje Ø125
I	Allacciamento alla rete fognaria - Connection to the sewer network Raccordement au tout-à-l'égout - Anschluss an das Abwassernetz Conexión a la red de alcantarillado

D FONDAZIONE, FOUNDATION, FONDATION, FUNDAMENT, FOSA

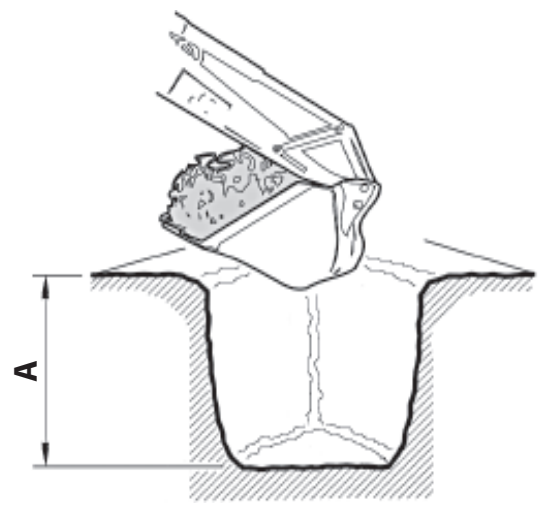

A = min. 1200 mm (STOPPY B 115/500)
min. 1400 mm (STOPPY B 200/700)

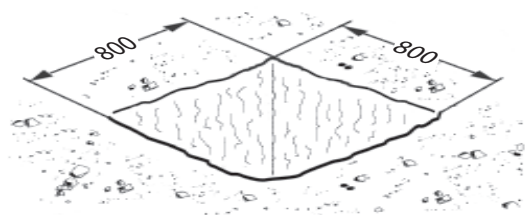

E DRENAGGIO, DRAINAGE, DRAINAGE, DRAINAGE, DRENAJE

P	STOPPY B 115/500	970 mm
	STOPPY B 200/700	1180 mm

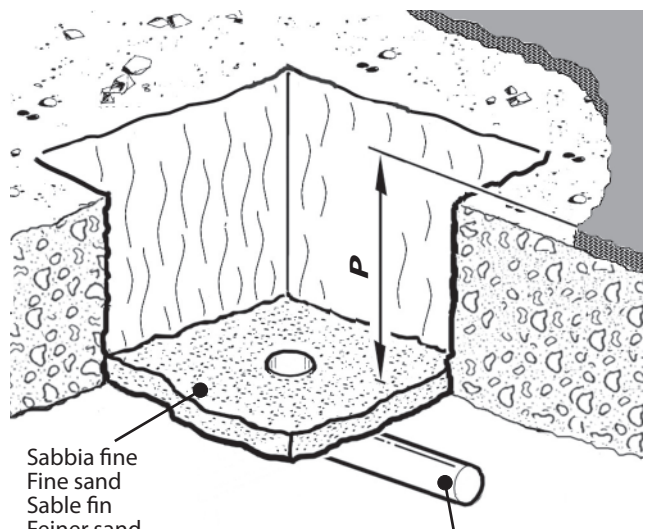

Sabbia fine
Fine sand
Sable fin
Feiner sand
Arena fina

Allacciamento alla rete fognaria
Connection to the sewer network
Raccordement au tout-à-l'égout
Anschluss an das Abwassernetz
Conexión a la red de alcantarillado

IT Assicurarsi che il terreno abbia un buon assorbimento d'acqua immettendo circa 40 litri d'acqua e verificando che lo svuotamento avvenga in meno di 30 minuti; in caso contrario realizzare il drenaggio delle acque tramite tubazioni da collegare ad ogni singola cassaforma e raccordate ad un tubo di drenaggio, oppure ad un pozzetto dotato di un sistema di svuotamento dell'acqua.

EN Ensure that the soil has a adequate water absorption by entering about 40 liters of water and checking that the emptying takes place in less than 30 minutes; otherwise realize the drainage of water through pipes connected to every single manhole and connected to a drainage pipe, or a collecting sump with a drainage system of water.

FR Avant de réaliser le coffrage, il faut vérifier la perméabilité du sol: le drainage minimum doit être de 80 litres/heure. Si l'évacuation de l'eau est trop faible, il est fortement recommandé soit de le raccorder à un tuyau de drainage, soit de construire un puit perdu.

DE Sicherstellen, dass das Gelände eine gute Wasseraufnahme gewährleistet, indem ca. 40 Liter Wasser eingefüllt und kontrolliert wird, dass das Wasser in weniger als 30 Minuten absickert. Andernfalls muss die Ableitung des Wassers anhand von Rohren erfolgen, an ein Abflussrohr anschließender mit einem mit Entwässerungssystem ausgestatteten Schacht zu verbinden sind.

ES Asegúrase de que el suelo tenga un buen absorbimiento del agua de aproximadamente 40 litros de agua, controlar que el vaciado sea efectuado en menos de 30 minutos; de lo contrario realice el drenaje a través de los tubos que deben ser conectados a cada encofrado del bolardo y a su vez conectado a una tubería de drenaje o a un buen sistema de drenaje.

F POSIZIONARE IL DISSUASORE, FIT THE BOLLARD, POSITIONNER LA BORNE, DEN POLLER EINSETZEN, COLOCAR EL POSTE

Senso di marcia
Running direction
Sens de marche
Fahrtrichtung
Dirección de marcha

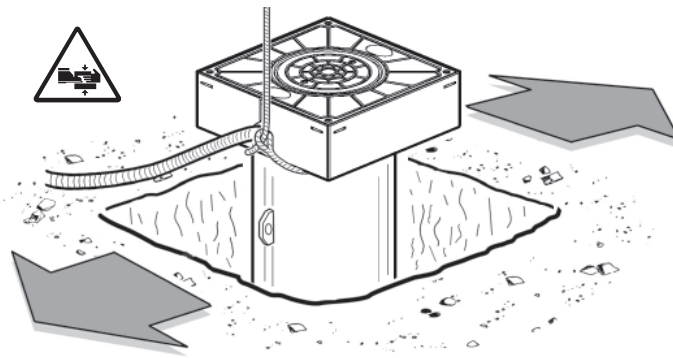

Senso di marcia
Running direction
Sens de marche
Fahrtrichtung
Dirección de marcha

G RIEMPIRE DI SABBIA FINO A ~200 MM DAL PIANO STRADALE, FILL WITH SAND TO ~200 MM FROM THE ROAD SURFACE, REMPLIR AVEC DU SABLE JUSQU'À ~200MM DU PLAN DE LA ROUTE, BIS AUF ~200 MM VON DER STRASSENEBENE MIT SAND BEFUELLEN, LLENAR DE ARENA HASTA ~200 MM DEL NIVEL DE LA CALZADA

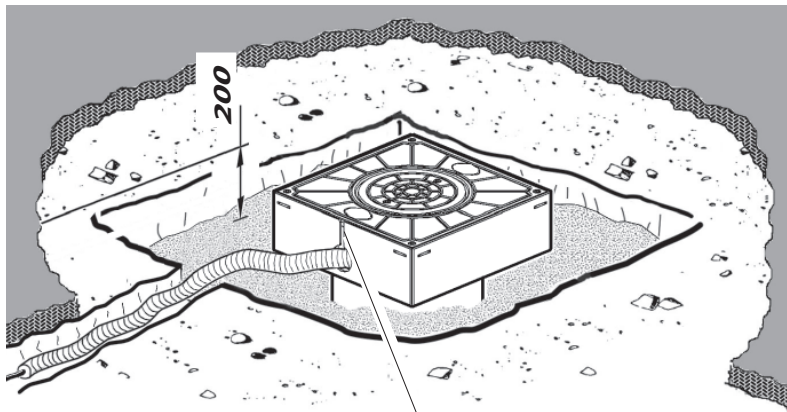

Proteggere l'apertura del passaggio cavi con nastro adesivo

Protect with tape the opening where the cables are fed
Protéger l'ouverture du passage des câbles avec du ruban adhésif
Schützen Sie mit Klebeband die Öffnung, wo die Kabel eingespeist werden
Proteger la apertura del paso de cables con cinta

H POSARE LA RETE ELETTROSALDATA E RIEMPIRE DI CEMENTO / LAY THE ELECTROWELDED MESH AND FILL WITH CONCRETE / POSER LA GRILLE ELECTRO-SOUDÉE ET REMPLIR DE CIMENT / DIE BAUSTAHLMATTE VERLEGEN UND FÜLLEN SIE MIT ZEMENT / COLOCAR LA REJILLA ELECTROSOLDADA E Y LLENAR CON CEMENTO

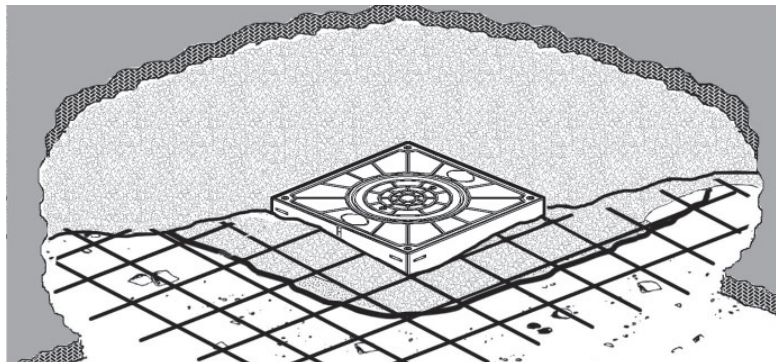

I COMPLETARE LA PAVIMENTAZIONE, FLOORING COMPLETION, COMPLETER LE SOL, DEN BODENBELAG FERTIGSTELLEN, TERMINAR EL PAVIMENTO

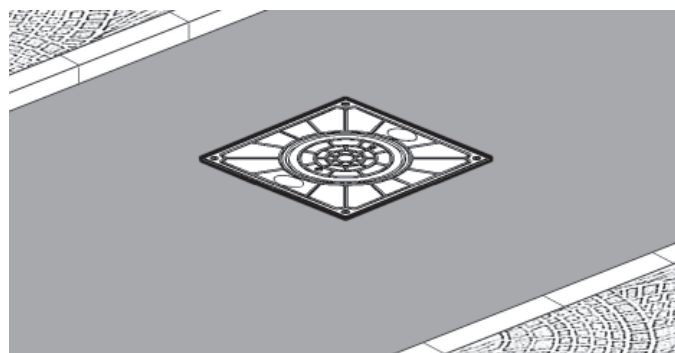

L COLLEGAMENTI ELETTRICI, ELECTRICAL CONNECTIONS, BRANCHEMENTS ELECTRIQUES, ELEKTRISCHE ANSCHLÜSSE, CONEXIONES ELÉCTRICAS

1 PERSEO CBD

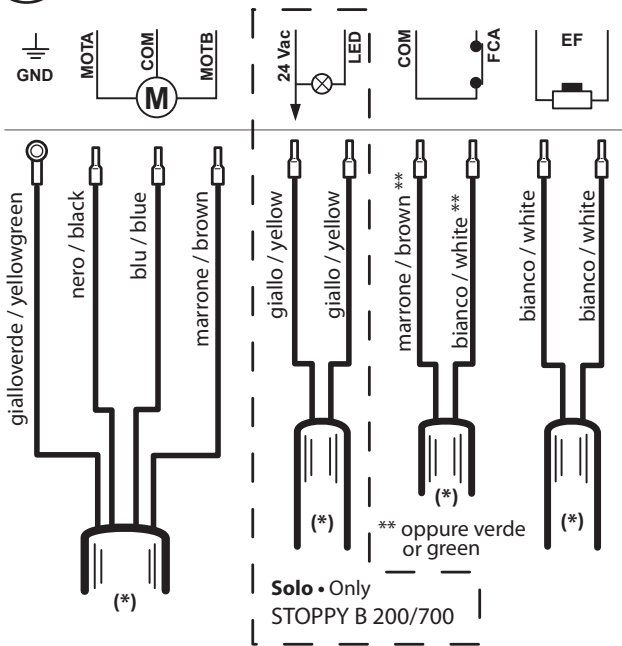

PERSEO CBD

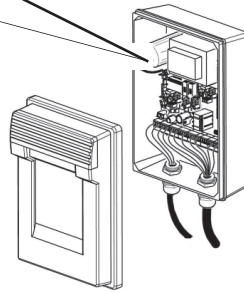

Isolare i cavi non utilizzati
Isolate unused cable
Isoler les conducteurs inutilisés
Isolieren Sie das Kabel unbenutzte
Aísle el cable no utilizado

Consultare il manuale d'installazione e uso della centralina PERSEO CBD.
Consult the **PERSEO CBD** control unit's installation and operating manual.
Consulter le manuel d'installation et d'utilisation de la centrale **PERSEO CBD**.
Die Installations und Bedienungsanleitungen der Steuereinheit **PERSEO CBD** nachschlagen.
Consultar el manual de instalación y uso de la centralita **PERSEO CBD**.

(*) **Cavo dissuasore • Cable from bollard**
Câble bollard • Poller-Kabel • Cable de bolardo

2 PERSEO CBE

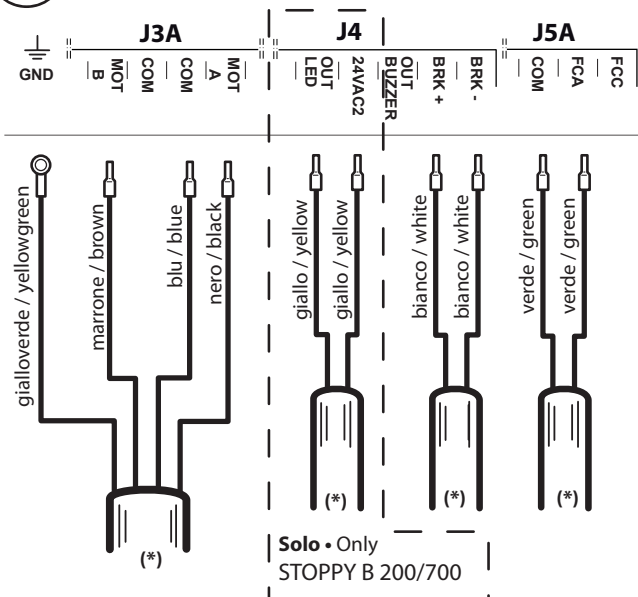

PERSEO CBE

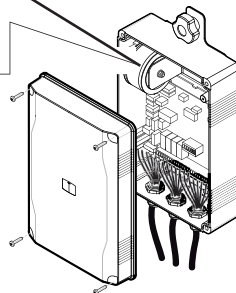

Isolare i cavi non utilizzati
Isolate unused cable
Isoler les conducteurs inutilisés
Isolieren Sie das Kabel unbenutzte
Aísle el cable no utilizado

Consultare il manuale d'installazione e uso della centralina PERSEO CBE.
Consult the **PERSEO CBE** control unit's installation and operating manual.
Consulter le manuel d'installation et d'utilisation de la centrale **PERSEO CBE**.
Die Installations und Bedienungsanleitungen der Steuereinheit **PERSEO CBE** nachschlagen.
Consultar el manual de instalación y uso de la centralita **PERSEO CBE**.

(*) **Cavo dissuasore • Cable from bollard**
Câble bollard • Poller-Kabel • Cable de bolardo

M MESSA IN FUNZIONE, STARTING THE DEVICE, MISE EN SERVICE, INBETRIEBNAHME, PUESTA EN FUNCIONAMIENTO

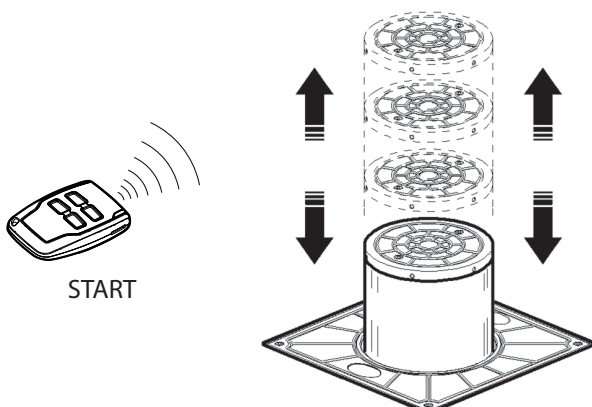

N SBLOCCO D'EMERGENZA, EMERGENCY RELEASE, DÉBLOCAGE D'URGENCE, NOTENTRIEGELUNG, DESBLOQUEO DE EMERGENCIA

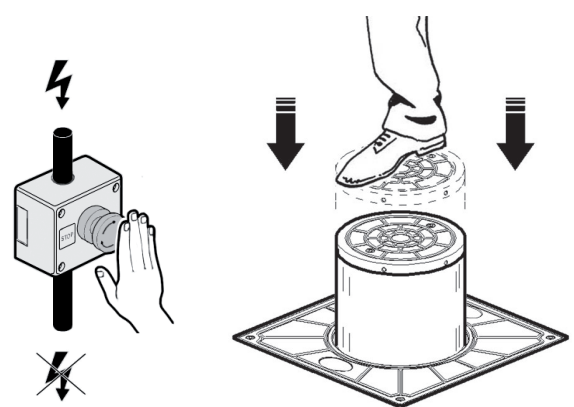

INSTALLATORE
INSTALLER
INSTALLATEUR
INSTALLATEUR
INSTALATOR

DATA
DATE
DATE
DATUM
FECHA



www.bft-automation.com

BFT Spa

Via Lago di Vico, 44 ITALY
36015 Schio (VI)
T +39 0445 69 65 11
F +39 0445 69 65 22

SPAIN

BFT GROUP ITALIBERICA DE AUTOMATISMOS SL
Camí de Can Bassa, 6, 08401 Granollers, Barcelona, Spagna

FRANCE

AUTOMATISMES BFT FRANCE SAS
50 rue jean zay
69800 Saint-Priest, Francia

GERMANY

BFT ANTRIEBSSYSTEME GMBH
Faber-Castell-Straße 29, 90522 Oberasbach, Germania

UNITED KINGDOM

BFT AUTOMATION UK LTD
Unit C2-C3 The Embankment Business Park, Vale Road Heaton Mersey Stockport Cheshire SK4 3GL United Kingdom

BFT AUTOMATION (SOUTH) LTD
Enterprise House Murdock Road, Dorcan, Swindon, England, SN3 5HY

PORTUGAL

BFT PORTUGAL SA
Urb. Pedrulha lote 9 - Apartado 8123, 3025-248 Coimbra Portugal

POLAND

BFT POLSKA SP ZOO
Marecka 49, 05-220 Zielonka, Polonia

IRELAND

BFT AUTOMATION IRELAND
Unit D3 City Link Business Park, Old Naas Road, Dublin

CROATIA

BFT ADRIA DOO
Obrovac 39, 51218, Dražice, Croazia

CZECH REPUBLIC

BFT CZ SRO
Ustecka 533/9, 184 00 Praha 8, Czech

TURKEY

BFT OTOMASYON KAPI
Şerifali Mahallesi, no, 34775 Ümraniye/Istanbul, Turchia

U.S.A.

BFT AMERICAS INC.
1200 S.W. 35th Avenue Suite B Boynton Beach FL 33426

AUSTRALIA

BFT AUTOMATION AUSTRALIA PTY
29 Bentley St, Wetherill Park NSW 2164, Australia

EMIRATES

BFT MIDDLEEAST FZCO
FZS2 AA01 -PO BOX 262200, Jebel Ali Free Zone South Zone 2, Dubai - United Arab

NEW ZEALAND

BFT AUTOMATION NEW ZEALAND
224/A Bush Road, Rosedale, Auckland, New Zealand