

# Couloir de passage à portes battantes

## Plan de mesure

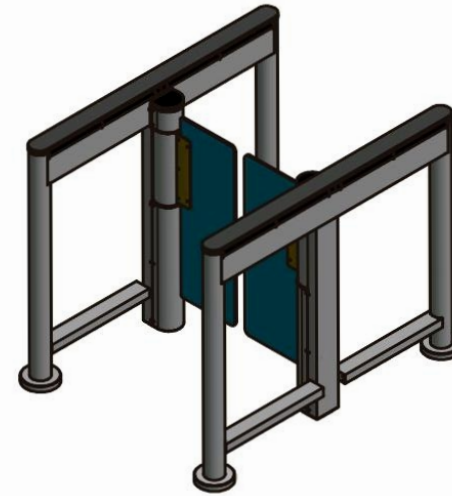
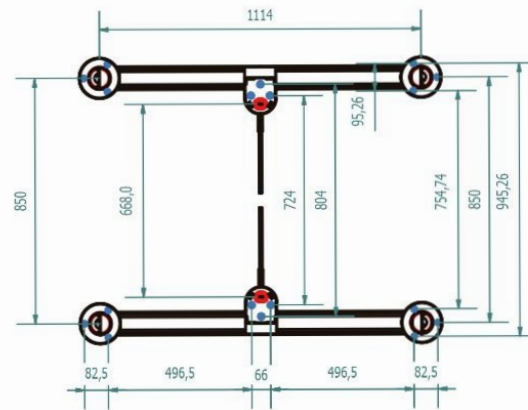
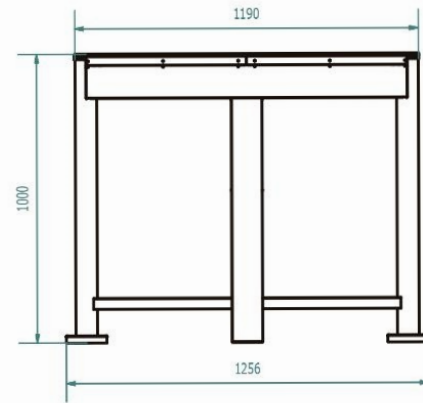
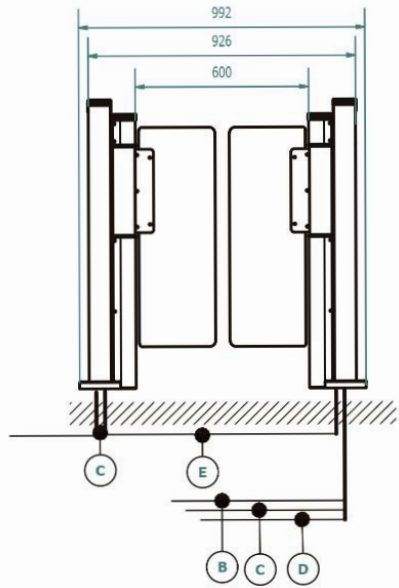

**LUX**  
**AUTOMATISMES**  
*WE OPEN WAYS*

136, rue de Bettembourg  
L 5811 FENTANGE  
+352 27 48 91 92

contact@lux-automatismes.lu  
www.lux-automatismes.lu