

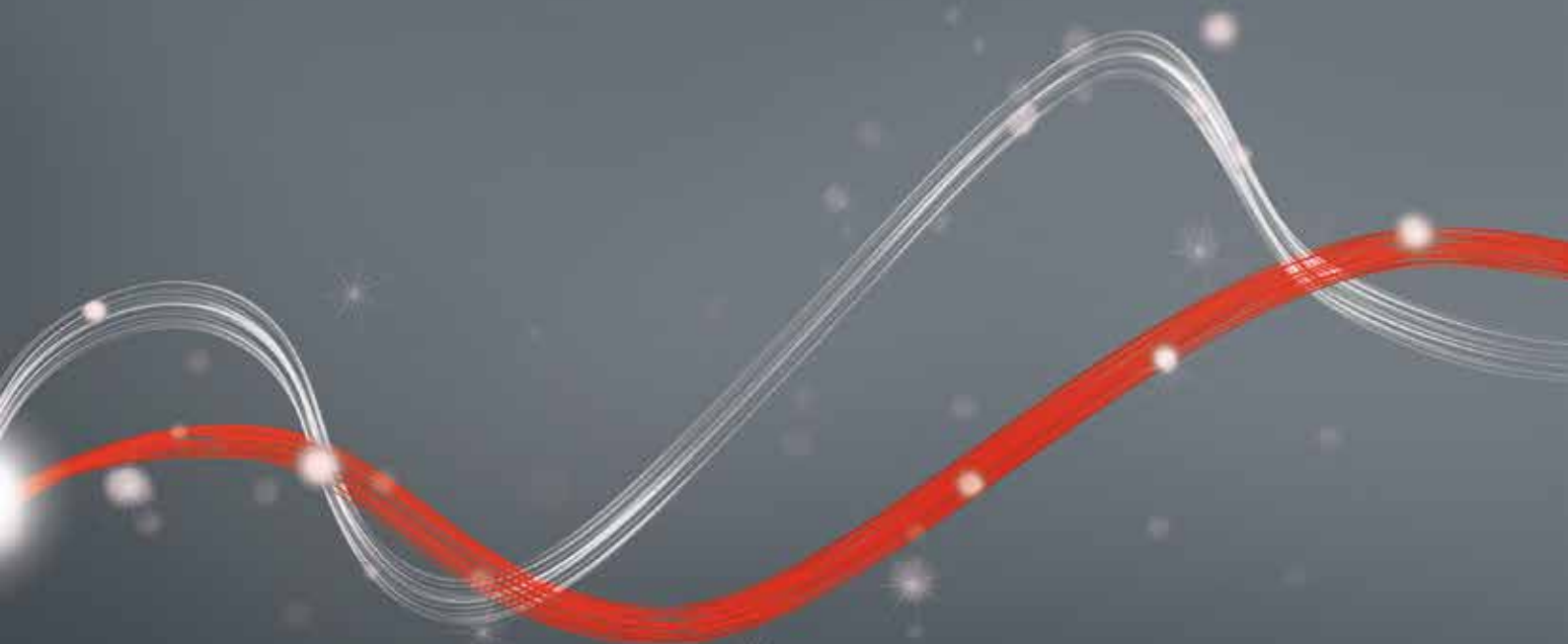

Be ahead



# ICARO VELOCE SMART AC A1000



## RANGE

• BENEFITS  
• PLUS

• CONTROL PANEL  
• TECHNICAL SPECIFICATIONS

• ACCESSORIES

• LEARN MORE ABOUT  
U-LINK



-  d-track
-  ee link
-  er ready
-  U-Link
-  Oil Gear



Empowered by  
**U-LINK**

**VELOCE**

A fast 230V gate operator which is suitable for very intensive use on sliding gates up to 1000kg. Speed without load 25m/min (the maximum speed of the leaf is dependent on the installation). This is extremely robust operator features an oil bath gearbox for higher performance. It is equipped with the exclusive D-Track torque management system and absolute encoder for precision movement. It features an electromagnetic limit switch for greater reliability and longevity. The control panel is U-Link compatible and is tamper-resistant. The Icaro Veloce is the ideal for sites which require fast operating speeds, reduced waiting times and high levels of security.

## ICARO VELOCE SMART AC A1000 | |

	Code	Name	Description
	P925256 00002	ICARO VELOCE SMART AC A 1000	230V operator for sliding gates up to 1000kg with absolute encoder. Speed without load 25m/min. Electromechanical limit switch. Equipped with mechanical safety clutch, torque management via D-Track technology and gear unit in oil bath. Control unit arranged for communication with U-link protocol and Tamper-proof function.

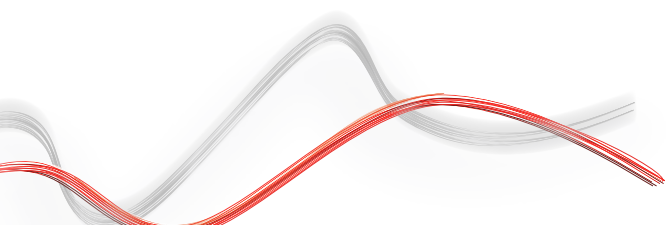

· RANGE

· BENEFITS  
· PLUS

· CONTROL PANEL  
· TECHNICAL SPECIFICATIONS

· ACCESSORIES

· LEARN MORE ABOUT  
U-LINK

## Benefits of ICARO VELOCE SMART AC A1000



**Speed:** The fast opening of the ICARO VELOCE SMART AC A1000 reduces waiting times, allowing quicker access, particularly useful for commercial and industrial sites.



**Security:** The fast operating speed means that the ICARO VELOCE SMART AC A1000 closes quickly, reducing the risk of entry by unauthorised people.



**U-Link:** The ICARO VELOCE SMART AC A 1000 operator is compatible with the U-Link communication protocol, through the integrated LEO B CBB control panel.



**D-Track:** An intelligent torque management system which updates the level of torque required to perform the operation, allowing it work at the optimum level regardless of weather conditions, temperature or the degree of wear and tear on the device.



**Oil Gear:** Oil bath gearbox unit. The component gears of the transmission are immersed in an oil bath to ensure perfect lubrication throughout their service life.

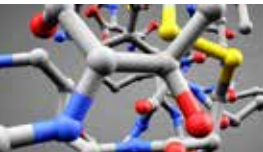

**Technopolymers:** The combined use of metal and plastic-technopolymer gears provides the perfect engagement between the surfaces, allowing for reduced friction and the highest levels of reliability in intensive use.



**Personalised key:** the lever release makes it easy to release the motor and the personalised key is unique, providing increased security.



**Screws on the front:** By putting the fastening screws on the front of the casing, installation and maintenance are easier and more convenient, even in confined spaces.

· RANGE

· BENEFITS  
· PLUS

· **CONTROL PANEL**  
· **TECHNICAL SPECIFICATIONS**

· ACCESSORIES

· **LEARN MORE ABOUT U-LINK**

## LEO B CBB L02



- Specific integrated control panel for the ICARO VELOCE SMART AC A1000, 230 V operator. Main features: removable colour coded terminal blocks, digital display for programming scenarios, integrated two-channel receiver, torque control with D-Track technology, slowdown during opening and closing. Main functions: automatic closing, fast closing, pedestrian opening.

	ICARO VELOCE SMART AC A1000
Control unit	LEO B CBB L02
Panel power supply	230 V
Motor voltage	230 V
Power consumption	750 W
Pinion module	4 mm (25 teeth)
Speed without load	25 m/min
max. weight	1,000 kg
max. torque	40 Nm
Impact reaction	8K2 safety edge (not supplied)
Locking	Mechanical
Manual operation	Mechanical release with lever
Type of use	Very intensive
Protection rating	IP24
Environmental conditions	-15 - +55°C

## Dimensions

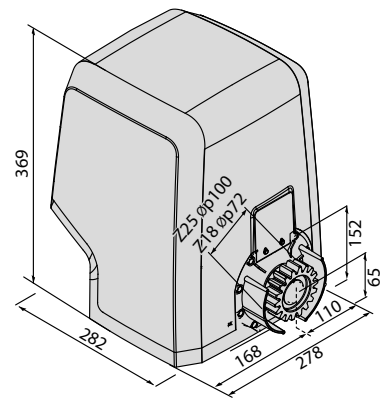

To ensure the highest safety standards in accordance with standard EN 12453, it is necessary to fit the 8K2 safety edge (not supplied. Please refer to the Instruction Manual for the 8K2 safety edge models to be used).

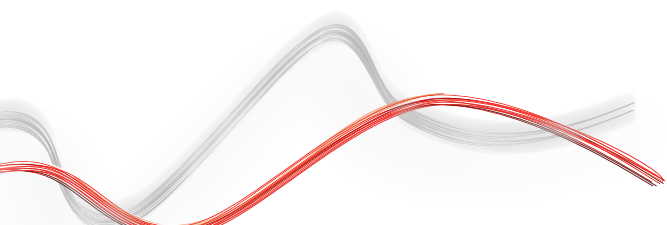

· RANGE

· BENEFITS  
· PLUS

· CONTROL PANEL  
· TECHNICAL SPECIFICATIONS

· ACCESSORIES

· LEARN MORE ABOUT  
U-LINK

## RECOMMENDED ACCESSORIES

	<b>D571054 - CFZ</b> Galvanized steel rack, module 4, 22 x 22 mm cross-section, length 2 m, fastened by welding. Maximum load 2,000 kg.		<b>N999156 - SFI</b> Mounting plate for ARES and ICARO (supplied with the operator)
	<b>P125018 - THEKE B PRA 01</b> Metal protective casing for sliding operators, ARES and ICARO series		<b>P111468 - B EBA RS 485 LINK</b> Expansion card for connection of groups of units with serial command management

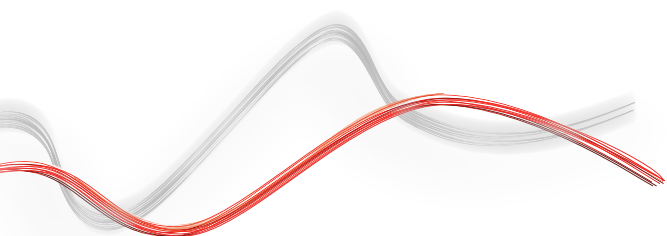

· RANGE

· BENEFITS  
· PLUS

· CONTROL PANEL  
· TECHNICAL SPECIFICATIONS

· ACCESSORIES

· **LEARN MORE  
ABOUT U-LINK**

## What is U-Link?

The innovative technology that gives you new power

An exclusive Bft innovation: U-Link (Universal Link) is an exclusive Bft platform that allows the creation of technological ecosystems. In Home Automation Access, it allows communication with all the home access automation devices of any brand. So you save time and can control everything with ease, without any worries.

### It is intuitive

Easy to install and use

### It is scalable

Allows an unlimited number of devices to be added

### It is flexible

Allows the creation of groups of interconnected products

### It is practical

Works with or without a web connection

### It is functional

Parameters can be controlled remotely via dedicated applications

- RANGE
- BENEFITS PLUS
- CONTROL PANEL TECHNICAL SPECIFICATIONS
- ACCESSORIES
- LEARN MORE ABOUT U-LINK

## Everything on one screen: find out more about this amazing technology

A world-exclusive platform that **can be used to create high-tech ecosystems** offering a vast range of solutions for many different sectors.

This proprietary platform which is a key feature of BFT products, thanks to the B-EBA cards and the Clonix U-Link receiver, is suitable for any protocol or product for access automation (including non-BFT ones and older versions) and it can be used in a variety of different sectors. This means any device becomes a smart device which can be interconnected with other systems, using a language that is becoming universal.



### U-Control HOME

Application for the remote management and control of a U-Link device. The device connects to the home wifi network using B-EBA wifi. The application can handle up to 6 users per B-EBA (administrator user + 5 guests).



### U-Base 2

A software package for installation, performing maintenance and identifying any faults in the U-Link compatible operators, easily and conveniently.



### U-SDK

U-SDK is the innovative application which allows BFT automations to be made compatible and easily integrated into a BMS network.



### Clonix U-Link

Connect legacy products and non-BFT products to U-Link systems.

Can older generation BFT operators or even non-BFT products be connected to U-Link? Yes, thanks to the Clonix receivers. Accessories which accept no limits.



### B-EBA

A direct link to your operators.

The B-EBA expansion boards make it possible to connect external devices such as PCs, smartphones and tablets to a BFT operator and a Clonix receiver or to connect multiple BFT products in a U-Link network. These accessories integrate with U-Link technology and with Bluetooth, Z-Wave and TCP/IP protocols as well as with the RS485 serial interface. A device that demonstrates exactly what BFT means by interconnectivity.

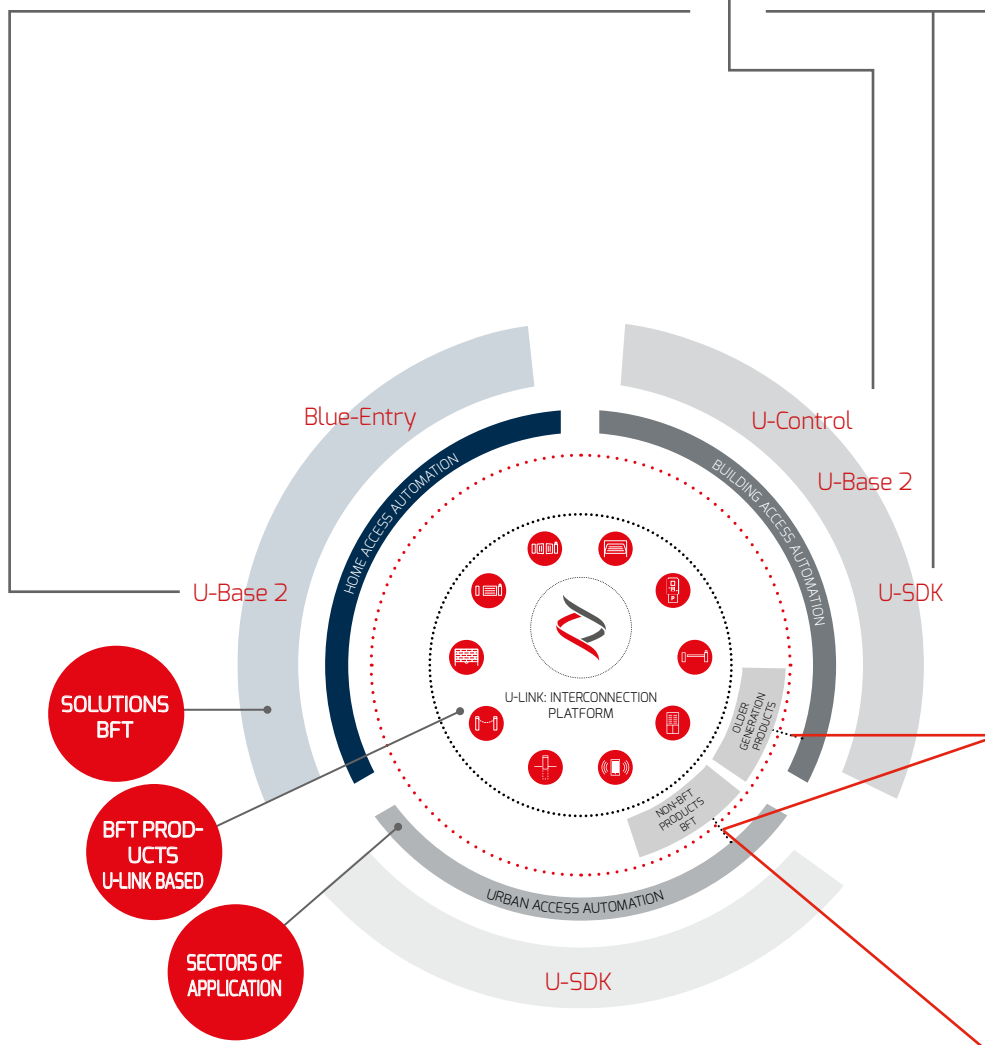



INFORMATION REGARDING THE PROTECTION OF THE INDUSTRIAL AND INTELLECTUAL PROPERTY RIGHTS OF BFT. BFT S.p.A. protects its industrial property by depositing trademarks, patents, models and designs. The intellectual property of BFT S.p.A. is protected by copyright law. BFT S.p.A. also protects its know-how by taking measures to protect the technical and commercial information inherent in its company and products. All the products in this catalogue are ORIGINAL BFT MODELS and only BFT S.p.A is authorised to produce them and market them anywhere in the world. All the commercial names in this catalogue are owned by BFT S.p.A., and only BFT S.p.A. is authorised to use them in relation to the corresponding merchandise category. **FALSIFIERS WILL BE PROCEEDED AGAINST IN ACCORDANCE WITH BOTH CIVIL AND CRIMINAL LAW. THESE CONDITIONS NOT ONLY GUARANTEE THE INTELLECTUAL PROPERTY RIGHTS OF BFT, BUT ALSO PROTECT CUSTOMERS BY GUARANTEEING THAT THE PRODUCTS THEY ARE PURCHASING ARE ORIGINAL BFT PRODUCTS RESULTING FROM STUDIES AND DESIGNS WITHIN THE BFT COMPANY.**